



Translation of the original
Operating manual

GA 3000SCEC
GA 3000SCEC Robot
GA 3000SCEC Robot Twin

Edition 01/2006

SupraCoat
Automatic gun
outside controlled

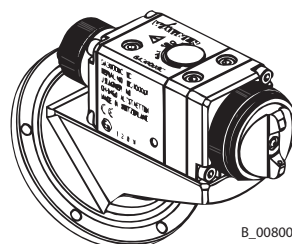
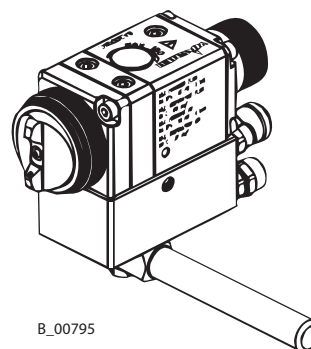
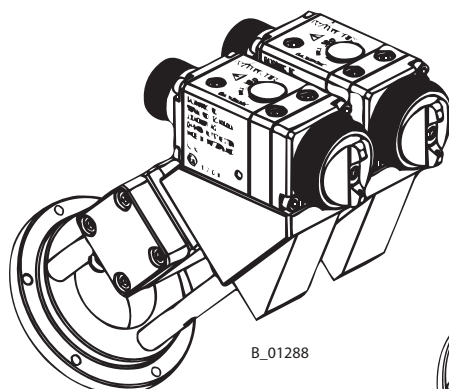

II 2GX (94/9/EG)

Contents

1	ABOUT THESE INSTRUCTIONS	5
1.1	Languages	5
1.2	Warnings, notes and symbols in these instructions	5
2	GENERAL SAFETY INSTRUCTIONS	6
2.1	Safety instructions for the operator	6
2.1.1	Electrical equipment	6
2.1.2	Personnel qualifications	6
2.1.3	A safe work environment	6
2.2	Safety instructions for personnel	6
2.2.1	Safe handling of WAGNER spray units	7
2.2.2	Earth the unit	7
2.2.3	Material hoses	7
2.2.4	Cleaning	8
2.2.5	Handling hazardous liquids, varnishes and paints	8
2.2.6	Touching hot surfaces	8
2.3	Correct use	8
2.4	Use in an explosion hazard area	9
2.4.1	Correct use	9
2.4.2	Explosion protection identification	9
2.4.3	Maxi. surface temperature	9
2.4.4	Safety instructions	9
3	PRODUCT LIABILITY AND WARRANTY	10
3.1	Important notes on product liability	10
3.2	Warranty	10
3.3	CE-conformity	11
3.4	German regulations and guidelines	11
4	DESCRIPTION	13
4.1	Field of application, using in accordance with the instructions	13
4.1.1	What kind of spraying material can be applied	13
4.2	Scope of supply	13
4.2.1	Classification	13
4.2.2	Overview	14
4.2.2.1	GA 3000SCEC -Variants	14
4.2.2.2	GA 3000SCEC Robot -Variants	15
4.2.2.3	GA 3000SCEC Robot Twin -Variants	15
4.3	Data	16
4.3.1	Technical data	16
4.3.2	Materials of paint wetted parts	16
4.3.3	Dimensions and Connections	17
4.3.4	Dimensions	18
4.4	Design of spray gun	20
4.5	Circulation operating mode	22
4.6	Functional description	22
4.7	Spraying process	23

Contents

5	STARTING UP AND OPERATION	24
5.1	Alignment and connection	24
5.1.1	Typical automatic installation	24
5.1.2	Ventilation of the spray booth	25
5.1.3	Air supply	25
5.1.4	Fluid (paint) hoses	25
5.1.5	Earthing the system	26
5.2	Preparation of paint	27
5.2.1	Viscosity conversion table	27
5.3	Starting up	28
5.3.1	General rules for handling spray gun	28
5.3.2	Preparation starting up	28
5.4	Operation	29
5.4.1	Start-up SC-spraying	29
5.4.2	Spray pattern selection	29
5.4.3	Adjusting the spray pattern	30
5.4.4	Changing amount of material	30
5.4.5	Changing nozzle	31
5.4.6	Adjustment of the packing in the gun head	32
6	MAINTENANCE	33
6.1	Finishing work and cleaning	34
6.2	Changing material hoses	35
6.3	Replacing parts of the gun	36
6.4	Replacing parts in the valve tappet	38
6.5	Reassembling	39
7	TROUBLESHOOTING AND SOLUTIONS	41
8	ACCESSORIES	42
8.1	Air caps	42
8.2	Nozzles	42
8.2.1	Output measured with water H ₂ O	43
8.3	Connections	44
8.3.1	Material	44
8.3.1.1	Kink protection for material connections	44
8.3.2	Atomizing air	44
8.3.3	Atomizing air/ Shaping air	44
8.4	Material circulation	44
8.5	Miscellaneous	45
9	SPARE PARTS CATALOGUE	47
9.1	How to order spare parts?	47
9.2	Spare parts list GA 3000SCEC	48
9.3	Spare parts list GA 3000SCEC UV	52
9.4	Spare parts list GA 3000SCEC Robot	55
9.5	Spare parts list GA 3000SCEC Robot UV	58
9.6	Spare parts list GA 3000SCEC Robot Twin	61
9.7	Spare parts list GA 3000SCEC Robot Twin UV	64
9.8	Spare parts list air valve	67
9.9	Overview of assemblies	69

1 ABOUT THESE INSTRUCTIONS

This operating manual contains information on the operation, repair and maintenance of the unit.

→ Always observe these instructions when operating the unit.

This equipment can be dangerous if it is not operated in accordance with this manual.

Compliance with these instructions constitutes an integral component of the warranty agreement.

1.1 LANGUAGES

This operating manual is available in the following languages:

Language:	Part No.	Language:	Part No.
German	383870	English	383871
French	383872	Dutch	383873
Italian	383874	Spanish	383875
Danish	383877	Swedish	383876

1.2 WARNINGS, NOTES AND SYMBOLS IN THESE INSTRUCTIONS

Warning instructions in this manual point out particular dangers to users and equipment and state measures for avoiding the hazard. These warning instructions fall into the following categories:

Danger - imminent danger. Non-observance will result in death, serious injury and serious material damage.

 SIHI_0100_GB	⚠ DANGER
	<p>This line warns of the hazard! Possible consequences of failing to observe the warning instructions. The signal word points out the hazard level.</p> <p>→ The measures for preventing the hazard and its consequences.</p>

Warning - possible danger. Non-observance can result in death, serious injury and serious material damage.

 SIHI_0103_GB	⚠ WARNING
	<p>This line warns of the hazard! Possible consequences of failing to observe the warning instructions. The signal word points out the hazard level.</p> <p>→ The measures for preventing the hazard and its consequences.</p>

Caution - a possibly hazardous situation. Non-observance can result in minor injury.

 SIHI_0101_GB	⚠ CAUTION
	<p>This line warns of the hazard! Possible consequences of failing to observe the warning instructions. The signal word points out the hazard level.</p> <p>→ The measures for preventing the hazard and its consequences.</p>

Caution - a possibly hazardous situation. Non-observance can cause material damage.

SIHI_0102_GB	CAUTION
<p>This line warns of the hazard! Possible consequences of failing to observe the warning instructions. The signal word points out the hazard level.</p> <p>→ The measures for preventing the hazard and its consequences.</p>	

Note - provide information on particular characteristics and how to proceed.

2 GENERAL SAFETY INSTRUCTIONS

2.1 SAFETY INSTRUCTIONS FOR THE OPERATOR

- Keep these operating instructions to hand near the unit at all times.
- Always follow local regulations concerning occupational safety and accident prevention.



2.1.1 ELECTRICAL EQUIPMENT

Electrical plant and unit

- To be provided in accordance with the local safety requirements with regard to the operating mode and ambient influences.
- May only be maintained by skilled electricians or under their supervision.
- Must be operated in accordance with the safety regulations and electrotechnical regulations.
- Must be repaired immediately in the event of problems.
- Must be put out of operation if they pose a hazard.
- Must be de-energized before work is commenced on active parts. Inform staff about planned work, observe electrical safety regulations.



2.1.2 PERSONNEL QUALIFICATIONS

- Ensure that the unit is operated and repaired only by trained persons.

2.1.3 A SAFE WORK ENVIRONMENT

- Ensure that the floor of the working area is anti-static in accordance with EN 50053 Part 1, §7-2, measurement in accordance with DIN 51953.
- Ensure that all persons within the working area wear anti-static shoes, e.g. shoes with leather soles.
- Ensure that during spraying, persons wear anti-static gloves so that they are earthed via the handle of the spray gun.
- Customer to provide paint mist extraction systems conforming to local regulations.
- Ensure that the following components of a safe working environment are available:
 - Material/air hoses adapted to the working pressure
 - Personal safety equipment (breathing and skin protection)
- Ensure that there are no ignition sources such as naked flame, glowing wires or hot surfaces in the vicinity. Do not smoke.



2.2 SAFETY INSTRUCTIONS FOR PERSONNEL

- Always follow the information in these instructions, particularly the general safety instructions and the warning instructions.
- Always follow local regulations concerning occupational safety and accident prevention.



2.2.1 SAFE HANDLING OF WAGNER SPRAY UNITS

The spray jet is under pressure and can cause dangerous injuries.

Avoid injection of paint or cleaning agents:

- Never point the spray gun at people.
- Never reach into the spray jet.
- Before all work on the unit, in the event of work interruptions and functional faults:
 - Switch off the energy/compressed air supply.
 - Secure the spray gun against actuation.
 - Relieve the pressure from the spray gun and unit.
 - By functional faults: Identify and correct the problem, proceed as described in chap. „Trouble shooting“.

In the event of skin injuries caused by paint or cleaning agents:

- Note down the paint or cleaning agent that you have been using.
- Consult a doctor immediately.

Avoid danger of injury through recoil forces:

- Ensure that you have a firm footing when operating the spray gun.
- Only hold the spray gun briefly in any one position.

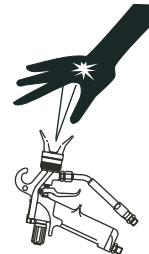

2.2.2 EARTH THE UNIT

Electrostatic charges can occur on the unit due to the electrostatic charge and the flow speed involved in spraying. These can cause sparks and flames upon discharge.

- Ensure that the unit is always earthed.
- Earth the work pieces to be coated.
- Ensure that all persons inside the working area are earthed, e.g. that they are wearing antistatic shoes.
- When spraying, wear antistatic gloves to earth yourself via the spray gun handle.



2.2.3 MATERIAL HOSES

- Ensure that the hose material is chemically resistant to the sprayed materials.
- Ensure that the material hose is suitable for the pressure generated in the unit.
- Ensure that the following information is visible on the high-pressure hose:
 - Manufacturer
 - Permissible operating overpressure
 - Date of manufacture.
- The electrical resistance of the complete high-pressure hose must be less than 1 MOhm.



2.2.4 CLEANING

- De-energize the unit electrically.
- Disconnect the pneumatic supply line.
- Relieve the pressure from the unit.
- Ensure that the flash point of the cleaning agent is at least 5 K above the ambient temperature.
- To clean, use only solvent-free cloths and brushes. Never use hard objects or spray on cleaning agents with a gun.

An explosive gas/air mixture forms in closed containers.

- When cleaning units with solvents, never spray into a closed container.
- Earth the container.



2.2.5 HANDLING HAZARDOUS LIQUIDS, VARNISHES AND PAINTS

- When preparing or working with paint and when cleaning the unit, follow the working instructions of the manufacturer of the paints, solvents and cleaning agents being used.
- Take the specified protective measures, in particular wear safety goggles, protective clothing and gloves, as well as hand protection cream if necessary.
- Use a mask or breathing apparatus if necessary.
- For sufficient health and environmental safety: Operate the unit in a spray booth or on a spraying wall with the ventilation (extraction) switched on.
- Wear suitable protective clothing when working with hot materials.



2.2.6 TOUCHING HOT SURFACES

- Touch hot surfaces only if you are wearing protective gloves.
- When operating the unit with a coating material with a temperature of >43°C; 109.4°F:
 - Identify the unit with a warning label that says „Warning - hot surface“.

**Order No.**

9998910 Information label

9998911 Safety label

2.3 CORRECT USE

WAGNER accepts no liability for any damage arising from incorrect use.

- Use the unit only to work with the materials recommended by WAGNER.
- Operate the unit only as an entire unit.
- Do not deactivate safety equipment.
- Use only WAGNER original spare parts and accessories.



2.4 USE IN AN EXPLOSION HAZARD AREA

2.4.1 CORRECT USE

The unit is suitable for working liquid materials in accordance with the classification into explosion classes.

2.4.2 EXPLOSION PROTECTION IDENTIFICATION

As defined in the Directive 94/9/CE (ATEX 95), the unit is suitable for use in areas where there is an explosion hazard.

CE  II 2G X



- CE: Communautés Européennes
 Ex: Symbol for explosion protection
 II: Unit class II
 2: Category 2 (Zone 1)
 G: Ex-atmosphere gas
 X: See: "Special Notes" in the operating manual

2.4.3 MAXI. SURFACE TEMPERATURE

X: The maximum surface temperature corresponds to the permissible material temperature. This and the permissible ambient temperature can be found in the Technical Data.

2.4.4 SAFETY INSTRUCTIONS

Safe handling of WAGNER spray units

Mechanical sparks can form if the unit comes into contact with metal.

In an explosive atmosphere:

- Do not knock or push the unit against steel or rusty iron.
- Do not drop the spray gun.
- Use only tools that are made of a permitted material.

Ignition temperature of the coating material

→ Ensure that the ignition temperature of the coating material is above the maximum surface temperature.

Medium supporting atomizing

→ To atomize the material, use only weakly oxidizing gases, e.g. air.

Cleaning

If there are deposits on the surfaces, the unit may form electrostatic charges. Flames or sparks can form if there is a discharge.

→ Remove deposits from the surfaces to maintain conductivity.

3 PRODUCT LIABILITY AND WARRANTY

3.1 IMPORTANT NOTES ON PRODUCT LIABILITY

As a result of an EC regulation, effective as from January 1, 1990, the manufacturer shall only be liable for his product if all parts come from him or are approved by him, and if the devices are properly fitted, operated and maintained.

If other makes of accessory and spare parts are used, the manufacturer's liability could be fully or partially null and void.

The usage of original WAGNER accessories and spare parts guarantees that all safety regulations are observed.

3.2 WARRANTY

This unit is covered by our warranty on the following terms:

We will at our discretion repair or replace free of charge all parts which within 24 months in single-shift, 12 months in 2-shift or 6 months in 3-shift operation from date of receipt by the Purchaser are found to be wholly or substantially unusable due to causes prior to the sale, in particular faulty design, defective materials or poor workmanship.

The terms of the warranty are met at our discretion by the repair or replacement of the unit or parts thereof. The resulting costs, in particular shipping charges, road tolls, labour and material costs will be borne by us except where these costs are increased due to the subsequent shipment of the unit to a location other than the address of the purchaser.

This warranty does not cover damage caused by:

Unsuitable or improper use, faulty installation or commissioning by the purchaser or a third party, normal wear, negligent handling, defective maintenance, unsuitable coating products, substitute materials and the action of chemical, electrochemical or electrical agents, except when the damage is attributable to us.

Abrasive coating products such as redlead, emulsions, glazes, liquid abrasives, zinc dust paints and similar reduce the service life of valves, packings, spray guns, nozzles, cylinders, pistons etc. Any wear resulting from the aforementioned causes is not covered by this warranty.

Components not manufactured by Wagner are subject to the warranty terms of the original maker.

The replacement of a part does not extend the warranty period of the unit.

The unit should be inspected immediately upon receipt.

To avoid loss warranty, any apparent defect should be notified to us or the dealer in writing within 14 days from date of sale of the unit.

The right to commission warranty services to a third party is reserved.

Warranty claims are subject to proof of purchase by submitting an invoice or delivery note. If an inspection finds damage not covered by the present warranty, the repair will be carried out at the expense of the purchaser.

Note that this warranty does not in any way restrict legally entitled claims or those contractually agreed to in our general terms and conditions.

3.3 CE-CONFORMITY

Herewith we declare that the supplied version of:



GA 3000SCIC	383001	383002	383003	383004	383005	383006	383007	383008
GA 3000SCEC	383010	383011	383012	383013	383014	383015	383016	383017
GA 3000SCEC Robot	383020	383021	383022	383023	383024	383025	383026	383027
GA 3000SCEC Robot Twin	383060	383061	383062	383063	383064	383065	383066	383067

Complies with the following guidelines:

94/9/EG (Atex-directives)

Applied standards, in particular:

DIN EN ISO 12100-1	DIN EN ISO 3746
DIN EN ISO 12100-2	DIN EN 1050
DIN EN 563	DIN EN 1127-1
DIN EN 809	DIN EN 13463-1

Applied national technical standards and specifications, in particular:

BGI 764	BGR 500
---------	---------

Marking:

**CE Certificate of Conformity**

The certificate is enclosed with this product. The certificate of conformity can be reordered from your WAGNER representative, quoting the product and serial number.

Part number:

GA 3000SC 383890

3.4 GERMAN REGULATIONS AND GUIDELINES

- a) BGV D15 Working with liquid ejection devices
- b) BGV D25 Using coating materials
- c) CHV 9 Regulations on flammable liquids
- d) BGR 104 Explosion protection rules
- e) BGR 132 Avoiding ignition risks
- f) BGR 180 Setting up for cleaning with solvents for cleaning workpieces with solvents
- g) ZH 1/406 Guidelines for liquid ejection devices
- h) BGI 740 Painting rooms and equipment

Note: All titles can be ordered from Heymanns Publishing House in Cologne or download from Internet.

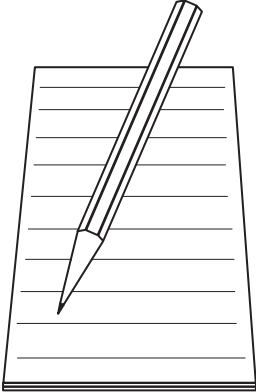

A series of horizontal lines for writing, starting from the top right and extending down the page.

4 DESCRIPTION

4.1 FIELD OF APPLICATION, USING IN ACCORDANCE WITH THE INSTRUCTIONS

The gun is suitable for atomising liquid materials, particularly coating materials, using the SupraCoat Spray-process.

4.1.1 WHAT KIND OF SPRAYING MATERIAL CAN BE APPLIED

- Solvent and water based lacquers
- Acrylic paints
- Polyester based paints
- Textured and special effect paints

Note:

In the event of application problems, contact your WAGNER branch and the paint manufacturer.

4.2 SCOPE OF SUPPLY

4.2.1 CLASSIFICATION

<u>GA</u>	<u>3000</u>	<u>SC</u>	<u>XX</u>	<u>XX</u>
①	②	③	④	⑤

- ① GA = Automatic gun
- ② 3000 = Gun type
- ③ SC = SupraCoat -> high volume low pressure spraying system
- ④ IC = Shaping and atomizing air controlled via valve within gun.
EC = Shaping and atomizing air controlled via valve outside of gun.
- ⑤ C = Circulation
NC = No circulation

4.2.2 OVERVIEW

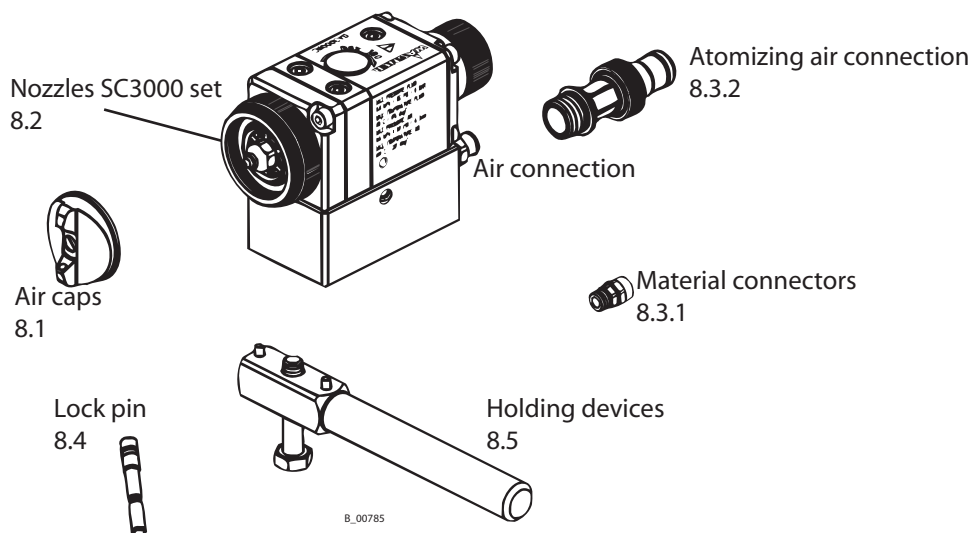

The SC automatic spray gun is composed of standard variant and supplement equipment. Circulation operating mode is possible.

4.2.2.1 GA 3000SCEC -VARIANTS

Part No.	Description
383010 to 383017	SupraCoat automatic gun GA 3000SCEC
383040 to 383047	SupraCoat automatic gun GA 3000SCEC USA

The standard equipment includes:

383010	383011	383012	383013	383014	383015	383016	383017	383040	383041	383042	383043	383044	383045	383046	383047	SupraCoat automatic gun GA 3000SCEC	
Quantity																Part No.	Description
-	-	-	-	-	-	-	1	-	-	-	-	-	-	-	1	383937	Nozzle SC3000 0.3 set
1	-	-	-	-	-	-	-	1	-	-	-	-	-	-	-	383930	Nozzle SC3000 0.5 set
-	1	-	-	-	-	-	-	-	1	-	-	-	-	-	-	383931	Nozzle SC3000 0.8 set
-	-	1	-	-	-	-	-	-	-	1	-	-	-	-	-	383932	Nozzle SC3000 1.0 set
-	-	-	1	-	-	-	-	-	-	-	1	-	-	-	-	383933	Nozzle SC3000 1.25 set
-	-	-	-	1	-	-	-	-	-	-	-	1	-	-	-	383934	Nozzle SC3000 1.6 set
-	-	-	-	-	1	-	-	-	-	-	-	-	1	-	-	383935	Nozzle SC3000 2.0 set
-	-	-	-	-	-	1	-	-	-	-	-	-	-	1	-	383936	Nozzle SC3000 2.5 set
1	1	1	1	1	1	1	1	1	1	1	1	1	1	1	1	383890	CE-Declaration of Conformity
1	1	1	1	1	1	1	1	-	-	-	-	-	-	-	-	383870	Operating manual German
-	-	-	-	-	-	-	-	1	1	1	1	1	1	1	1	383871	Operating manual English
1	1	1	1	1	1	1	1	1	1	1	1	1	1	1	1	See chap. 1	An operating manual in the local language

For special versions the delivery note applies.

4.2.2.2 GA 3000SCEC ROBOT -VARIANTS

Part-No.	Description
383020 to 383027	SupraCoat Automatic gun GA 3000SCEC Robot
383050 to 383057	SupraCoat Automatic gun GA 3000SCEC Robot (USA edition)

The standard equipment includes:

383020	383021	383022	383023	383024	383025	383026	383027	383050	383051	383052	383053	383054	383055	383056	383057	SupraCoat Automatic gun GA 3000SCEC Robot	
Quantity															Part-No.	Description	
-	-	-	-	-	-	-	1	-	-	-	-	-	-	-	1	383937	Nozzle SC3000 0.3 set
1	-	-	-	-	-	-	-	1	-	-	-	-	-	-	-	383930	Nozzle SC3000 0.5 set
-	1	-	-	-	-	-	-	-	1	-	-	-	-	-	-	383931	Nozzle SC3000 0.8 set
-	-	1	-	-	-	-	-	-	-	1	-	-	-	-	-	383932	Nozzle SC3000 1.0 set
-	-	-	1	-	-	-	-	-	-	-	1	-	-	-	-	383933	Nozzle SC3000 1.25 set
-	-	-	-	1	-	-	-	-	-	-	-	1	-	-	-	383934	Nozzle SC3000 1.6 set
-	-	-	-	-	1	-	-	-	-	-	-	-	1	-	-	383935	Nozzle SC3000 2.0 set
-	-	-	-	-	-	1	-	-	-	-	-	-	-	1	-	383936	Nozzle SC3000 2.5 set
1	1	1	1	1	1	1	1	1	1	1	1	1	1	1	1	383890	CE-Declaration of Conformity
1	1	1	1	1	1	1	1	-	-	-	-	-	-	-	-	383870	Operating manual German
-	-	-	-	-	-	-	-	1	1	1	1	1	1	1	1	383871	Operating manual English
1	1	1	1	1	1	1	1	1	1	1	1	1	1	1	1	See chap. 1	An operating manual in the local language

4.2.2.3 GA 3000SCEC ROBOT TWIN -VARIANTS

Part-No.	Description
383060 to 383067	SupraCoat Automatic gun GA 3000SCEC Robot Twin

The standard equipment includes:

383060	383061	383062	383063	383064	383065	383066	383067	SupraCoat Automatic gun GA 3000SCEC Robot Twin	
Quantity							Part-No.	Description	
-	-	-	-	-	-	-	2	383937	Nozzle SC3000 0.3 set
2	-	-	-	-	-	-	-	383930	Nozzle SC3000 0.5 set
-	2	-	-	-	-	-	-	383931	Nozzle SC3000 0.8 set
-	-	2	-	-	-	-	-	383932	Nozzle SC3000 1.0 set
-	-	-	2	-	-	-	-	383933	Nozzle SC3000 1.25 set
-	-	-	-	2	-	-	-	383934	Nozzle SC3000 1.6 set
-	-	-	-	-	2	-	-	383935	Nozzle SC3000 2.0 set
-	-	-	-	-	-	2	-	383936	Nozzle SC3000 2.5 set
1	1	1	1	1	1	1	1	383890	CE-Declaration of Conformity
1	1	1	1	1	1	1	1	383870	Operating manual German
1	1	1	1	1	1	1	1	See chap. 1	An operating manual in the local language

For special versions the delivery note applies.

4.3 DATA**4.3.1 TECHNICAL DATA**

Description	Units	GA 3000SCEC	GA 3000SCEC Robot	GA 3000SCEC Robot Twin
Maxi. air pressure	MPa bar psi	0.6 6 87	0.6 6 87	0.6 6 87
Maxi. material pressure	MPa bar psi	0.8 8 116	0.8 8 116	0.8 8 116
Control air range ***	MPa bar psi	0.4 - 0.6 4 - 6 58 - 87	0.4 - 0.6 4 - 6 58 - 87	0.4 - 0.6 4 - 6 58 - 87
Material flow volume	l/min cc/min	* *	* *	* *
Weight (standard variant)	g oz	933 32.9	1236 43.6	3878 136.8
Maxi. temperature material	°C °F	80 176	80 176	80 176
Maxi. temperature air	°C °F	110 230	110 230	110 230
Ambient temperature	°C °F	5 - 40 41 - 104	5 - 40 41 - 104	5 - 40 41 - 104
Sound level at 0.6 MPa; 6 bar; 87 psi air pressure and 0.8 MPa; 8 bar; 116 psi material pressure **	dB(A)	82	82	82

* According to nozzle, see chapter 8

**A rated sound pressure level measured in 0.5 m distance according to DIN EN ISO 3746-1995

*** In the case of the GA 3000SCEC Robot Twin model the atomizing air pressure must always be at least 1 bar smaller than the control air pressure at the air valve.

4.3.2 MATERIALS OF PAINT WETTED PARTS

Metal		Plastics	
Tungsten carbide	Stainless steel 1.4104	UHMW-PE	FPM
Stainless steel 1.4034	Aluminium nickel plated	PTFE	POM
Stainless steel 1.4305	Brass nickel plated		

4.3.3 DIMENSIONS AND CONNECTIONS

Description	Units	GA 3000SCEC	GA 3000SCEC Robot	GA 3000SCEC Robot Twin
CA = Control air	Inch	G 1/8	G 1/8	G 1/8
C = Material circulation	Inch	G 1/4	G 1/4	G 1/4
AA = Atomizing air	Inch	G 1/2	G 1/2	G 1/2
M = Material	Inch	G 1/4	G 1/4	G 1/8
SA = Shaping air	Inch	G 1/8	G 1/8	G 1/8
CAL = Control air (air valve)	Inch	-	-	G 1/8

GA 3000SCEC

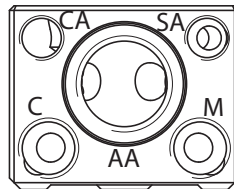

B_00814

GA 3000SCEC Robot

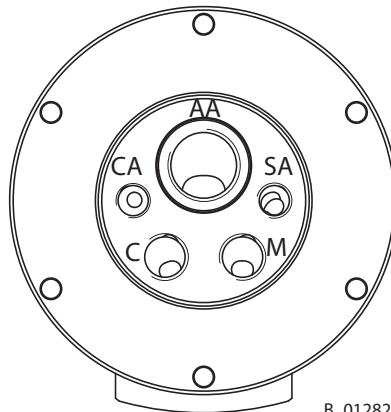

B_01282

GA 3000SCEC Robot Twin

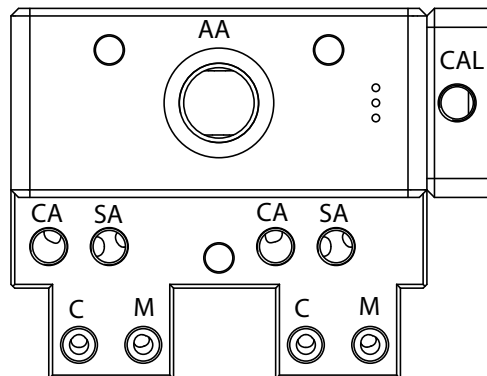

B_01283

4.3.4 DIMENSIONS

Dimensions	Units	GA 3000SEEC	GA 3000SEEC Robot	GA 3000SEEC Robot Twin
A	mm; inch	123.5 / 183.5 4.86 / 7.22	110 4.33	110 4.33
B	mm; inch	50 1.97	50 1.97	50 1.97
C	mm; inch	73 2.87	10 0.39	7 0.28
D	mm; inch	65 2.56	100.8 3.97	224.6 8.84
E	mm; inch	65 2.56	25 0.98	25 0.98
F	mm; inch	∅ 16 ∅ 0.63	59.8 ^{±0.1} 2.35 ^{±0.004}	59.018 2.32
G	mm; inch	115 4.52	8 0.31	11 0.43
H	mm; inch	92 3.62	117.1 4.61	236 9.29
I	mm; inch	18 ^{±0.1} 0.71 ^{±0.004}	38 1.50	203.5 8.01
K	mm; inch	18 ^{±0.1} 0.71 ^{±0.004}	∅ 100 ^{±0.2} ∅ 3.94 ^{±0.008}	∅ 100 ^{±0.2} ∅ 3.94 ^{±0.008}
L	mm; inch	146 5.75	165.6 6.52	189.3 7.45
M	mm; inch	-	-	257.8 10.15
N	mm, inch	-	-	110 4.33
O	mm; inch	-	-	128 5.04

GA 3000SEEC

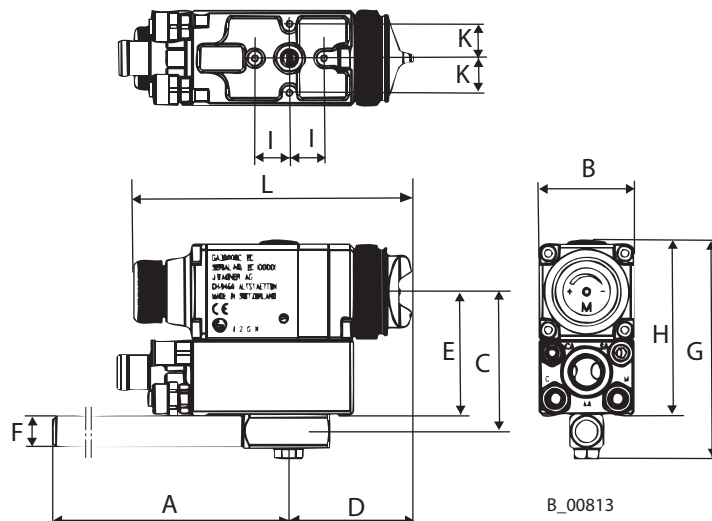

B_00813

GA 3000SCEC Robot

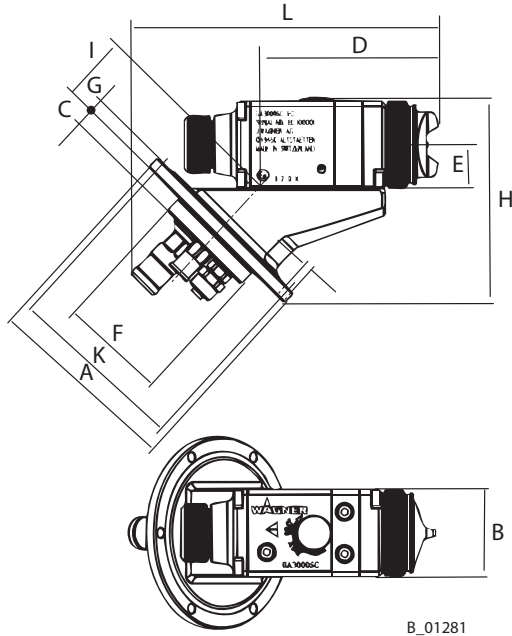

B_01281

GA 3000SCEC Robot Twin

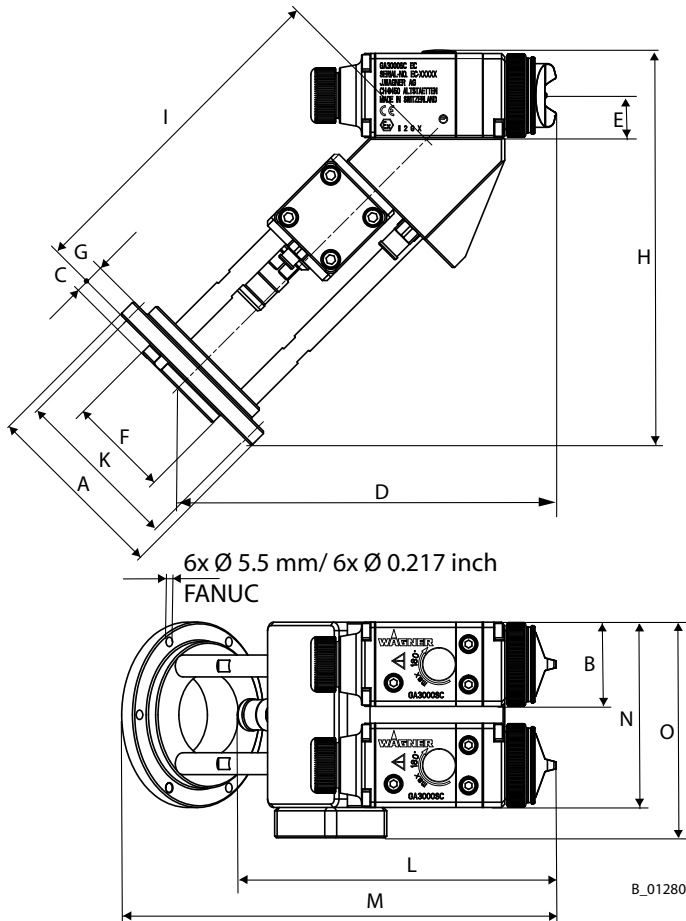

6x Ø 5.5 mm / 6x Ø 0.217 inch
FANUC

B_01280

4.4 DESIGN OF SPRAY GUN

	Description		Description
A	Gun head	J	Standard gun holder
B	Gun body	K	Connection nipple (material)
C	Jam sleeve	L	Connection nipple (circulation)
D	Base plate	M	Control air connection (red)
E	Connection atomizing air	N	Connection shaping air (green)
F	Throttle screw material	O	Spacer
G	Union nut	P	Air valve
H	Air cap	Q	Control air (air valve)
	Nozzle	R	Gun holder SC Twin

GA 3000SCEC

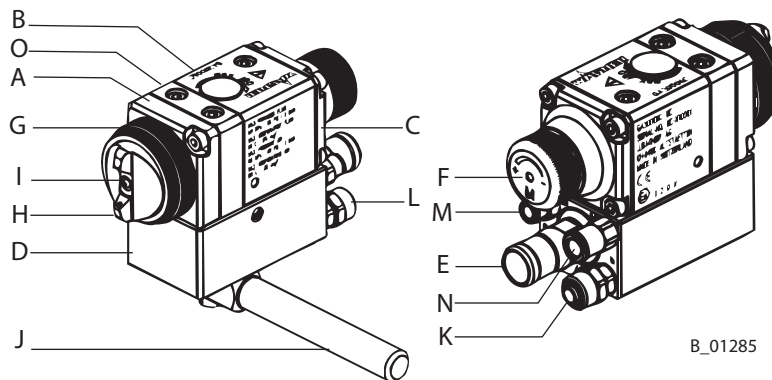

B_01285

GA 3000SCEC Robot

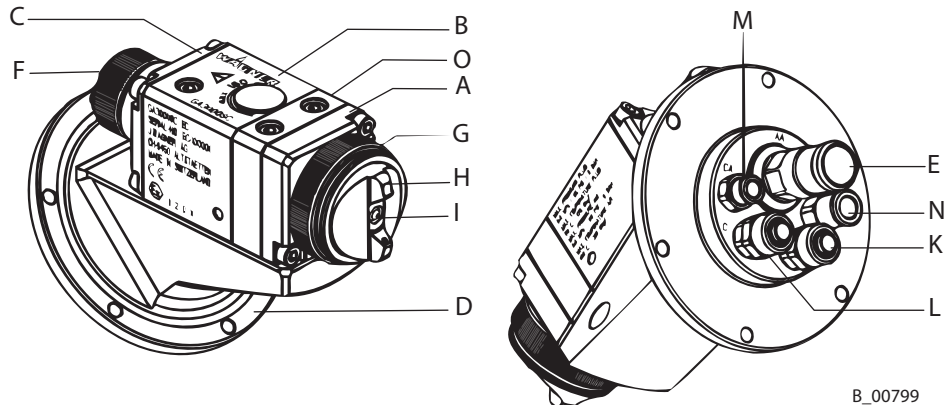

B_00799

The device consists of a gun head (A), gun body (B). At the gun head is cultivated the appropriate nozzle and diverse sections for the sealing and attachment. In the gun head the material valve and the packing are accommodated.

In the pistol body the clamping mechanism for the packing is inserted. The pistol body serves besides as connecting piece between the drive and the drive consists a diaphragm and a compression spring for the material valve.

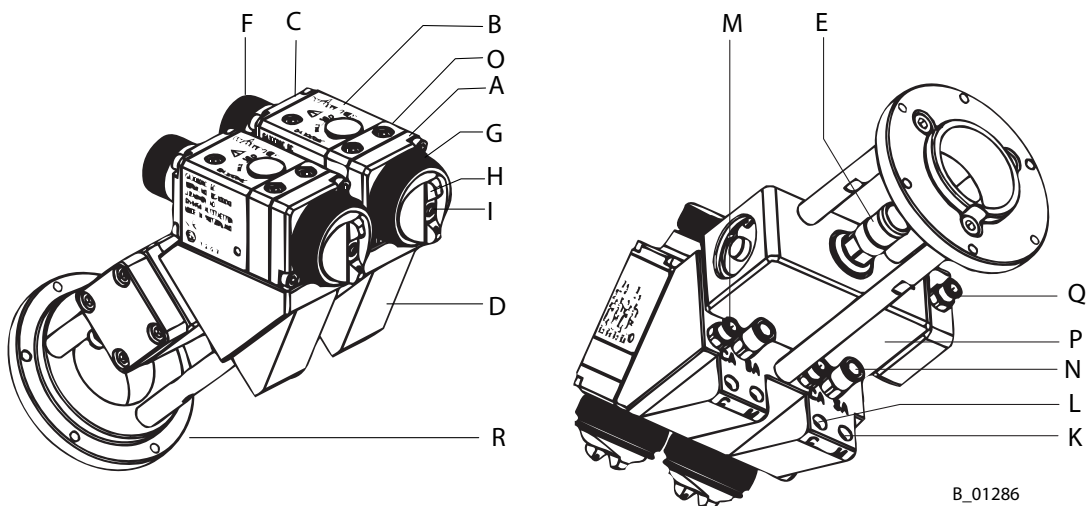

The base plate (D) contains all links (K, E, L and M). It can be used to mount the pistol at a reciprocator or at the standard gun holder.

GA 3000SCEC Robot Twin



At the Robot Twin model the atomizing air is passed to the left-hand or right-hand gun depending on the positioning of the air valve (P). The air valve (P) also has a control air connection (Q) that is used for switching. The base plate (D) as well as the air valve (P) are part of the carrier (R) at the Robot Twin model.

4.5 CIRCULATION OPERATING MODE

	 WARNING
	<p>The plug (P) is under high pressure! The plug can fly off like a projectile</p> <p>→ In NC mode (without material circulation), connect the gun only with the closing pin (O) fitted.</p>

SIHI_0007_GB

Mounting of stop pin - no circulation operating mode.

1. Detach gun body (B) from base plate (D).
2. Mount stop pin (O) into gun body.
3. Screw gun body (B) and base plate (D) together.
Ensure correct position of seals when doing so.
4. Tighten four screws to 4 Nm; 2.95 lbf.ft.
5. Mount sealing stopper (P)

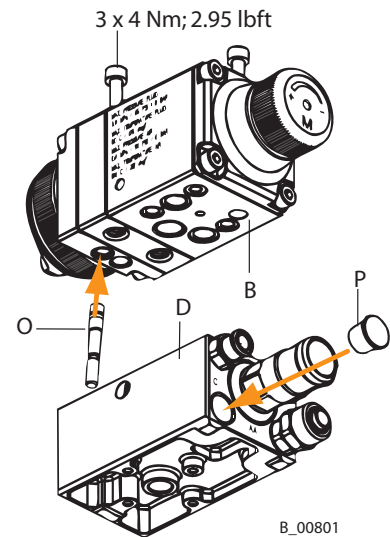
**4.6 FUNCTIONAL DESCRIPTION****Diagram GA 3000SCEC:**

SA = Shaping air
AA = Atomizing air
CA = Control air
M = Material
C = Circulation

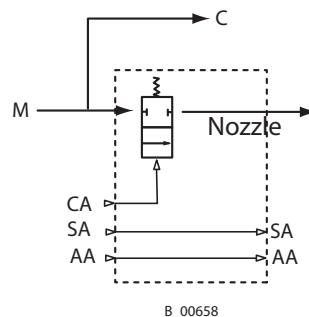
**Open:**

The diaphragm in the drive is then charged with control air and moves toward the rear. The material valve is then opened mechanically delayed. In this position, the coating material which is under pressure is applied to the work piece.

Close:

The diaphragm is relieved, and the material valve closes due to the pressure spring which presses against the material valve tappet.

Additional functions:

The pressure for the shaping air pressure and atomizing air is set via an external pressure controller. The two air streams are separated and can therefore be set independently of each other.

The material connections and the colour channels in the base plate are arranged so that several guns can be used in circulation operation.

Diagram GA 3000SCEC Robot Twin:

- SA = Shaping air
- AA = Atomizing air
- CA = Control air
- CAL = Control air (air valve)
- M = Material
- C = Circulation

In this variant the atomizer air is passed either to the first or the second gun via the air valve.

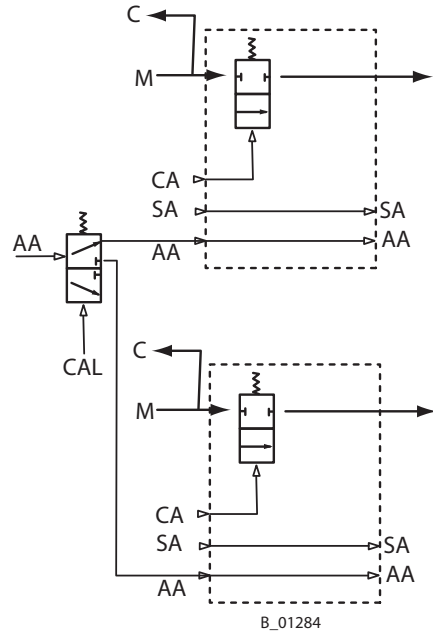

4.7 SPRAYING PROCESS

With the SupraCoat spraying process the spray material is atomized at a pressure of 0.05 - 0.2 MPa; 0.5 - 2 bar; 7.25 - 29 psi, maxi 0.8 MPa; 8 bar; 116 psi.
 A soft, flat spray is achieved with help of the atomizing air, which has a pressure of 0.02 - 0.07 MPa; 0.2 - 0.7 bar; 2.9 - 10.2 psi, maxi. 0.6 MPa; 6 bar; 87 psi.
 The shaping air provides the potential to make the width of the spray jet larger and smaller.

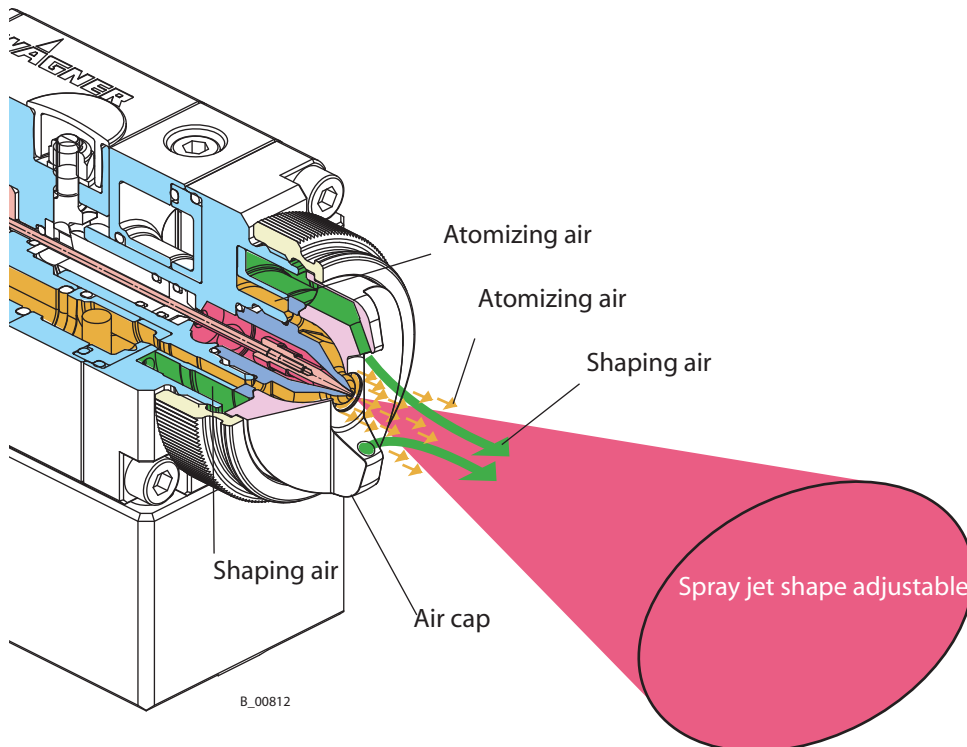

5 STARTING UP AND OPERATION

5.1 ALIGNMENT AND CONNECTION

5.1.1 TYPICAL AUTOMATIC INSTALLATION

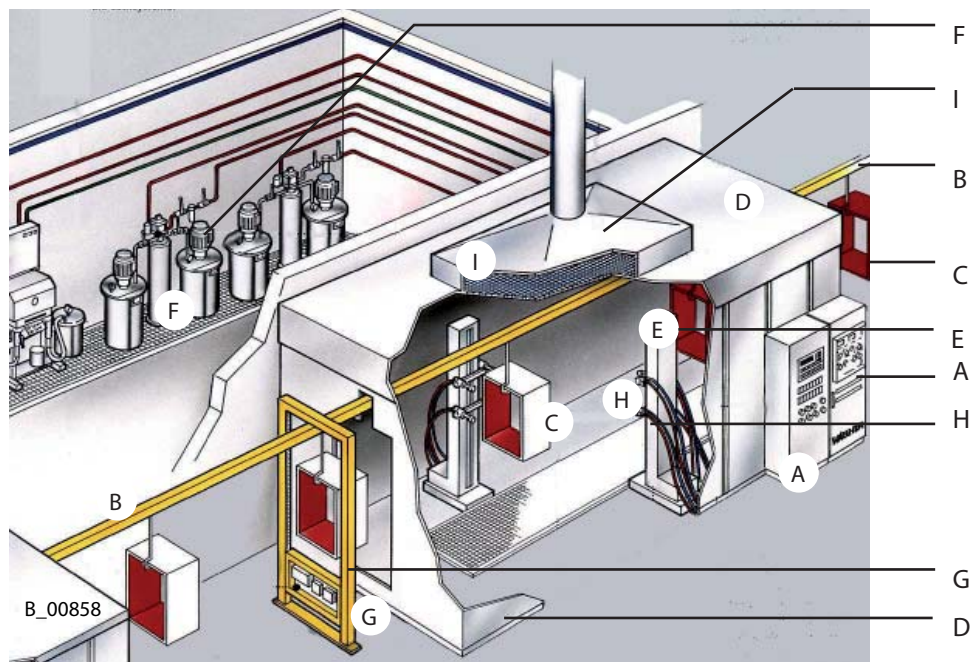



A	Control cabinet
B	Conveyer
C	Object
D	Spraying booth
E	Movement device system
F	Paint supply system
G	Part identification
H	Spray guns
I	Gasper air system and exhaust air system

The spray gun must be used a part of an SC spraying system. The spraying system shown in the figure is only one example. It is not an actual system design. Contact your WAGNER distributor for assistance in designing a system to meet your needs.

The operating instructions and the safety regulations for the additional system components used must be read before starting-up.

5.1.2 VENTILATION OF THE SPRAY BOOTH

	 WARNING
	<p>Toxic and/or flammable vapor mixtures! Risk of poisoning and burns</p> <p>→ Operate the unit in a spraying booth approved for the working materials. -or- → Operate the unit on an appropriate spraying wall with the ventilation (extraction) switched on. → Observe national and local regulations for the outgoing air speed.</p>

SIHI_0028_GB



5.1.3 AIR SUPPLY

The use of an air filter with the air generator ensures that only dry, clean atomising air gets into the spray gun. Dirt and moisture in the atomising air reduce the spraying quality and the appearance of the finished piece.

5.1.4 FLUID (PAINT) HOSES



CAUTION
<p>Impurities in the spraying system! Spray gun blockage, materials harden in the spraying system</p> <p>→ Flush the spray gun and paint supply with a suitable cleaning agent.</p>

SIHI_0001_GB



	 DANGER
	<p>Bursting hose, bursting threaded joints! Danger to life from injection of material</p> <p>→ Ensure that the hose material is chemically resistant. → Ensure that the spray gun, threaded joints and material hose between the unit and the spray gun is suitable for the pressure generated in the unit. → Ensure that the following information can be seen on the high-pressure hose: - Manufacturer - Permissible operating pressure - Date of manufacture.</p>

SIHI_0029_GB

5.1.5 EARTHING THE SYSTEM

	 WARNING
	<p>Discharge of electrostatically charged components in atmospheres containing solvents! Explosion hazard from electrostatic sparks or flames.</p> <p>→ Earth all unit components. → Earth the workpieces being painted.</p>

SIHL_0027_GB

	 WARNING
	<p>Heavy paint mist if earthing is insufficient! Risk of poisoning Insufficient paint application quality</p> <p>→ Earth all unit components. → Earth the workpieces being painted.</p>

SIHL_0003_GB

Any material containers and the unit must be connected by a potential equalisation (earth) cable.

5.2 PREPARATION OF PAINT

The viscosity of the paints is of great importance. The best results are obtained with paints between 14 and 24 DIN sec (measured in immersion flow cup DIN 4 mm; 0.16 inch).

Always observe the manufacturer's application instructions on the container or in the technical instruction sheet.

In the case of application problems contact the paint producer.

5.2.1 VISCOSITY CONVERSION TABLE

milli Pascal x Sec mPas	Centipoise	Poise	DIN Cup 4 mm ; 0.16 inch	Ford Cup 4	Zahn 2
10	10	0.1		5	16
15	15	0.15		8	17
20	20	0.2		10	18
25	25	0.25	14	12	19
30	30	0.3	15	14	20
40	40	0.4	17	18	22
50	50	0.5	19	22	24
60	60	0.6	21	26	27
70	70	0.7	23	28	30
80	80	0.8	25	31	34
90	90	0.9	28	32	37
100	100	1	30	34	41
120	120	1.2	33	41	49
140	140	1.4	37	45	58
160	160	1.6	43	50	66
180	180	1.8	46	54	74
200	200	2	49	58	82
220	220	2.2	52	62	
240	240	2.4	56	65	
260	260	2.6	62	68	
280	280	2.8	65	70	
300	300	3	70	74	
320	320	3.2			
340	340	3.4			
360	360	3.6	80		
380	380	3.8			
400	400	4	90		

5.3 STARTING UP

→ See **safety regulations** in Chapter 2.

5.3.1 GENERAL RULES FOR HANDLING SPRAY GUN

The following rules must be observed before any work is carried out on the equipment or during breaks in work.

	WARNING
	<p>Unintentional putting into operation! Risk of injury</p> <p>Before all work on the unit, in the event of work interruptions and functional faults:</p> <ul style="list-style-type: none"> → Switch off the energy/compressed air supply. → Relieve the pressure from the spray gun and unit. → Secure the spray gun against actuation. → By functional faults: Identify and correct the problem, proceed as described in chap. „Trouble shooting“.

SIHL_0065_GB

CAUTION
<p>Solvent in air conduit! Problems</p> <p>→ By cleaning the spraygun use with min. 0.05 MPa; 0.5 bar; 7.25 psi shaping air. Cleaning solvent must not get into the air ducts.</p>

SIHL_0064_GB

5.3.2 PREPARATION STARTING UP

	WARNING
	<p>The plug (P) is under high pressure! The plug can fly off like a projectile</p> <p>→ In NC mode (without material circulation), connect the gun only with the closing pin (O) fitted.</p>

SIHL_0007_GB

1. Mount the spray gun on the automatic movement system.
2. Connect material hoses to spray gun and to material supply system.
3. Connect control air hose and atomizing air hose to spray gun and to oil-free, dry air supply with regulator. Connect fan air hose.
4. Place air cap into the union nut and screw in.
Note:
Adjust desired jet position by means of air cap horn. Tighten union nut by hand.
5. Visually check the permissible pressures for all the system components.

6. Make sure that the spraying unit and all other conductive parts within the work area are earthed.
7. Set material pressure and use a suitable medium (solvent or water) to check that connections do not leak.
8. Relieve spray gun and unit pressure.

5.4 OPERATION

5.4.1 START-UP SC-SPRAYING

1. Set material pressure to approx. 0.05 MPa; 0.5 bar; 7.25 psi at air controller.
2. Set atomizing air to approx. 0.05 MPa; 0.5 bar; 7.25 psi.
3. Bring shaping air regulator into middle position.
4. Spray on a test object or a cardboard (switch on control air).
5. Determine the settings for the spray pattern, spray jet width, amount of material and amount of air, see chapter 5.5.2.

Note

Repeat point 4 and 5 until the optimum spray pattern is reached

5.4.2 SPRAY PATTERN SELECTION

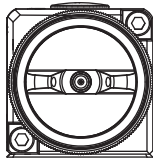

B_00792

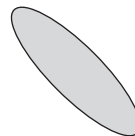
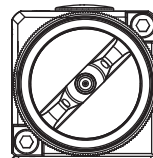
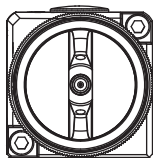

CAUTION

Paint may escape while control air is switched on!

Soiling.

→ Never switch on the control air while setting the air cap.

SIHI_0113_GB

1. Loosen union nut
2. Turn the air cap in the required spray pattern position.
3. Tighten union nut by hand.

5.4.3 ADJUSTING THE SPRAY PATTERN

The spray pattern can be adjusted to suit the object being sprayed using the shaping air regulator. The illustration below shows the influence of the shaping air regulator on the spraying pattern.

Other tip sizes can be used to obtain larger or smaller spraying patterns.

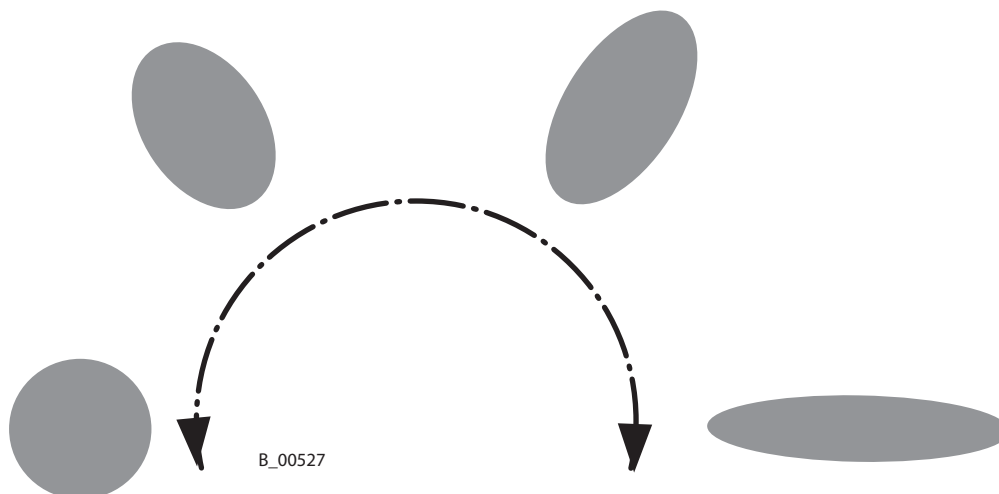

Shaping air valve
fully open

Shaping air valve
fully closed

5.4.4 CHANGING AMOUNT OF MATERIAL

The paint output volume can be changed by:

- Fitting another nozzle and valve needle. See accessories.
- Changing the material pressure.
- Tricks at the material throttle screw
 - Turn to the left => more material
 - Turn to the right => less material

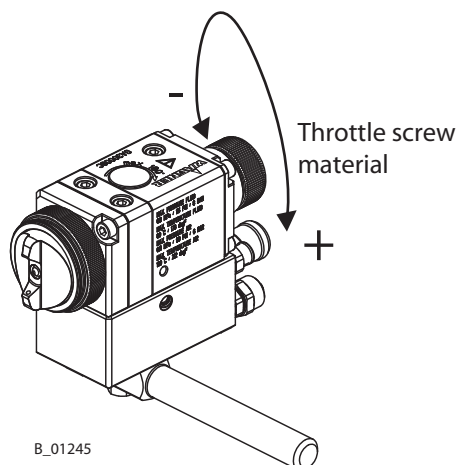

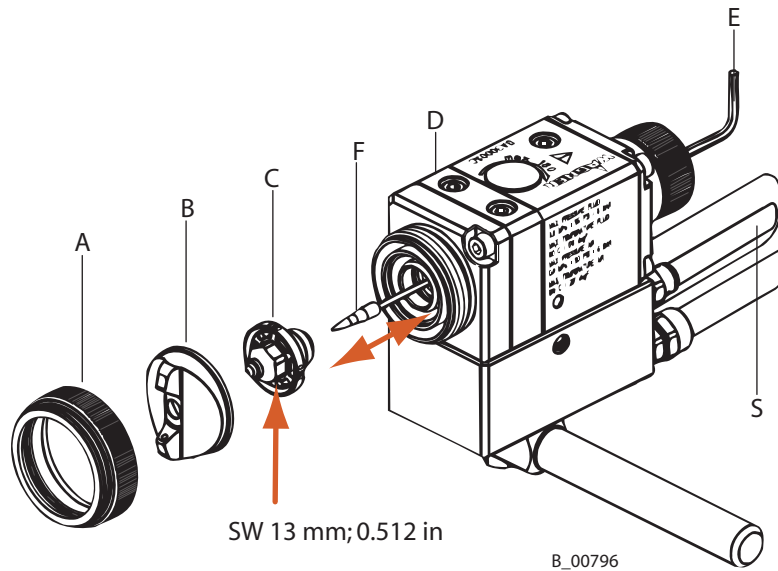
5.4.5 CHANGING NOZZLE**CAUTION****Strong friction between valve needle and nozzle while unscrewing!**

Damage to the sealing surfaces

→ Always turn on the control air before screwing in/unscrewing the nozzle (C).



SIHL_0114_GB

1. Take spray gun out of operation and clean.
2. Relieve the pressure from the spray gun and unit.
3. Unscrew union nut (A)
4. Remove air cap (B).
5. Switch on control air (S).
6. Unscrew nozzle (C) out of the gun head (D) by open end spanner SW 13 mm; 0.51 inch and brush with cleaning solvent until all remaining paint has been dissolved.
7. Switch off control air (S).
8. Loosen valve needle (F) using a hexagonal wrench 3 mm; 0.12 inch (E) and pull out valve needle (F)
9. Pull new valve needle (F) into the head gun as far as it will go and tighten with hexagonal wrench 3 mm (E).
10. Switch on control air (S).
11. Screw relevant nozzle (C) into gun head (D) and tighten with spanner 13 mm; 0.51 inch
12. Switch off control air (S).
13. Mount air cap (B) together with union nut (A).

5.4.6 ADJUSTMENT OF THE PACKING IN THE GUN HEAD

In case paint leaks at the valve rod near the area (Z):

1. Relieve the pressure from the gun and unit.
2. Secure spray gun. Remove control air hose (S).
3. Replace material with cleaning agent.
4. Unscrew union nut (A).
5. Remove air Cap (B)

	 DANGER
<p>Exploding gas/ air mixture! Danger to life from flying parts and burns</p>	
<p>→ Never spray into a closed container. → Earth the container.</p>	

SIHI_0008_GB

6. Pressurize the cleaning supply to approx. 0.2 MPa; 2 bar; 29 psi maxi. and thoroughly flush the spray gun.
7. Relieve the pressure from the spray gun and unit!
8. Remove plug (G).
9. Tighten the nut (I) carefully by turn maxi. 180° with socket spanner (B) SW 8 mm; 0.31 inch.
10. Mount air cap (B), union nut (A) and plug (G).
11. Connect control air hose. Switch the material pressure and the air pressure back on.
12. If leaking continues, change packing.

Note:

The packing can be retensioned maximally three times.

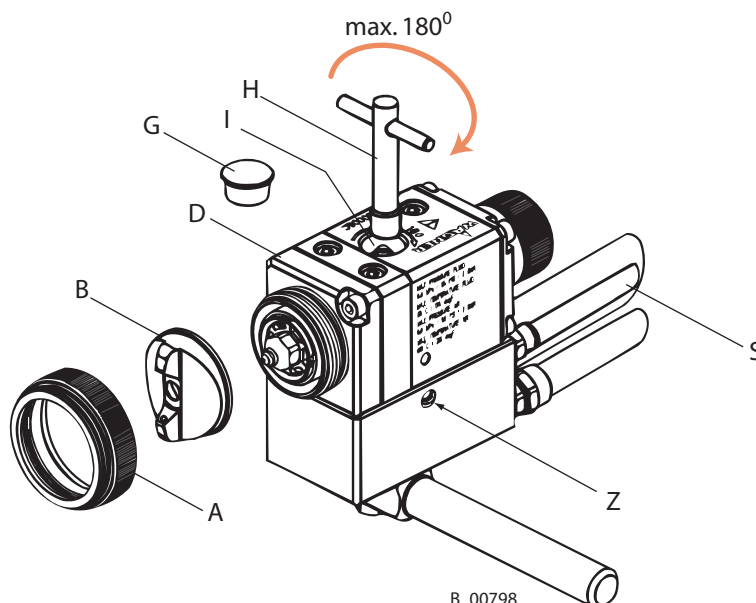

6 MAINTENANCE

→ See **safety regulations** in Chapter 2

The spray gun and the unit must be cleaned every day. Use only the cleaning solvent recommended by the material manufacture.

CAUTION

Impurities in the spraying system!

Spray gun blockage, materials harden in the spraying system

→ Flush the spray gun and paint supply with a suitable cleaning agent.

SIHI_0001_GB

CAUTION

Cleaning agent in the air duct!

Functional faults caused by swollen seals

→ Never immerse the spray gun in cleaning agent.

SIHI_0066_GB



WARNING

Incorrect maintenance/repair!

Risk of injury and damage to the equipment

- Repairs and part replacement may only be carried out by specially trained staff or a WAGNER service center.
- Before all work on the unit and in the event of work interruptions:
 - Switch off the energy/compressed air supply.
 - Relieve the pressure from the spray gun and unit.
 - Secure the spray gun against actuation.
- Observe the operating and service instructions when carrying out all work.

SIHI_0004_GB

6.1 FINISHING WORK AND CLEANING**CAUTION****Solvent in air conduit!**

Problems

- By cleaning the spraygun use with min. 0.05 MPa; 0.5 bar; 7.25 psi shaping air.
Cleaning solvent must not get into the air ducts.

SIHI_0064_GB

CAUTION**Strong friction between valve needle and nozzle while unscrewing!**

Damage to the sealing surfaces

- Always turn on the control air before screwing in/unscrewing the nozzle (C).

SIHI_0114_GB

**! DANGER****Exploding gas/ air mixture!**

Danger to life from flying parts and burns

- Never spray into a closed container.
→ Earth the container.

SIHI_0008_GB

**! WARNING****Explosive atmosphere!**

Explosive gases are produced when aluminium comes into contact with halogenized hydrocarbons.

- To clean aluminium, do not use liquids containing halogenized hydrocarbons.

SIHI_0009_GB

1. Relieve the pressure from the spray gun and unit.
2. Replace material with cleaning agent.
3. Unscrew union nut
4. Remove air cap.
5. Switch on control air.
6. Unscrew the nozzle using an open-end wrench 13 mm; 0.51 inch and clean.
7. Switch off control air.
8. Pressurize the cleaning supply to approx. 0.2 MPa; 2 bar; 29 psi maxi. and thoroughly flush the spray gun.
9. Relieve the pressure from the spray gun and unit !
10. Secure spray gun. (Remove control air hose).
11. Clean gun with a cleaning agent recommended by the manufacturer, and dry with a cloth.

6.2 CHANGING MATERIAL HOSES

1. Put out of operation and clean.
2. Relieve the pressure from the spray gun and unit.
3. Secure gun (remove control air hose).
4. Place open-ended wrench 14 mm; 0.55 inch on flats of paint connection and counter-hold.
5. Turn nut to the right with open-ended wrench 16 mm; 0.63 inch and unscrew material hose.
6. Pull material hose (B) out of the connection (C).

Mounting:

7. Fit the nut (A) over the material hose (B).
8. Insert material hose (B) into the connection (C) as far as it will go.
9. Fit the nut (A) with the open-ended wrench 16 mm; 0.63 inch and gently tighten.

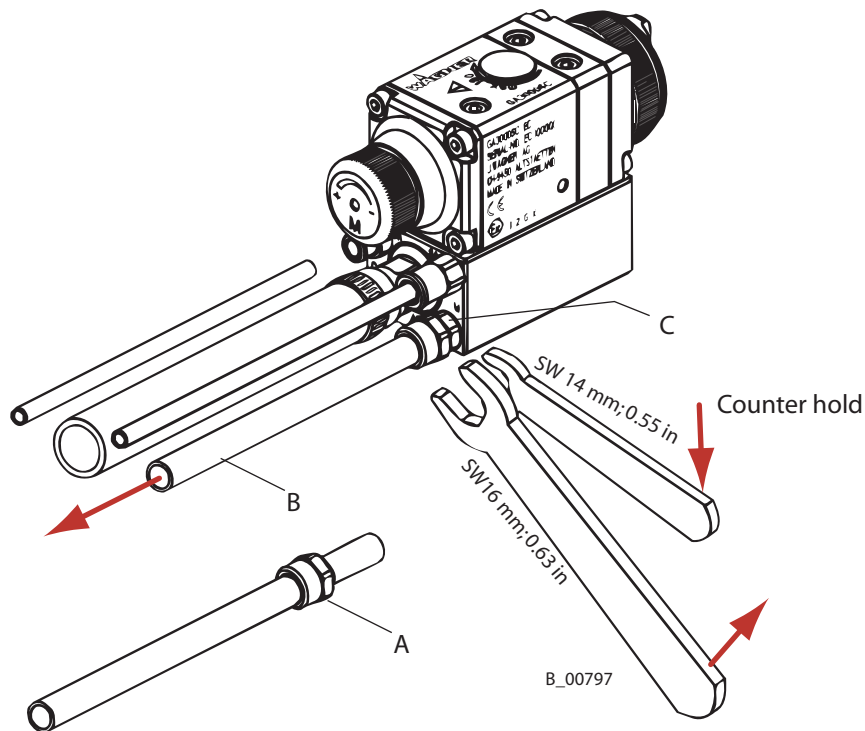

6.3 REPLACING PARTS OF THE GUN

Note:

Base plate assy. (B) must not be dismantled.

<p>CAUTION</p> <p>Strong friction between valve needle and nozzle while unscrewing! Damage to the sealing surfaces</p> <p>→ Always turn on the control air before screwing in/unscrewing the nozzle (C).</p>
--

SIHL_0114_GB

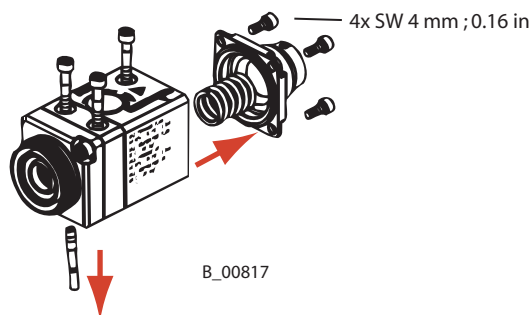
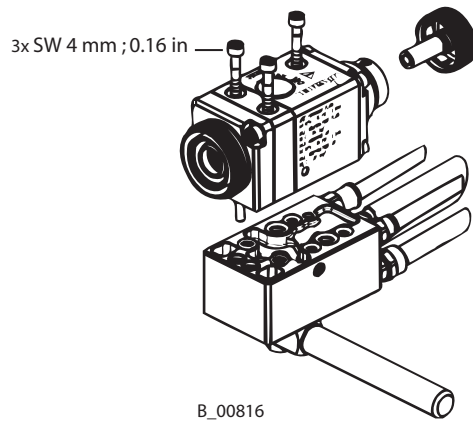
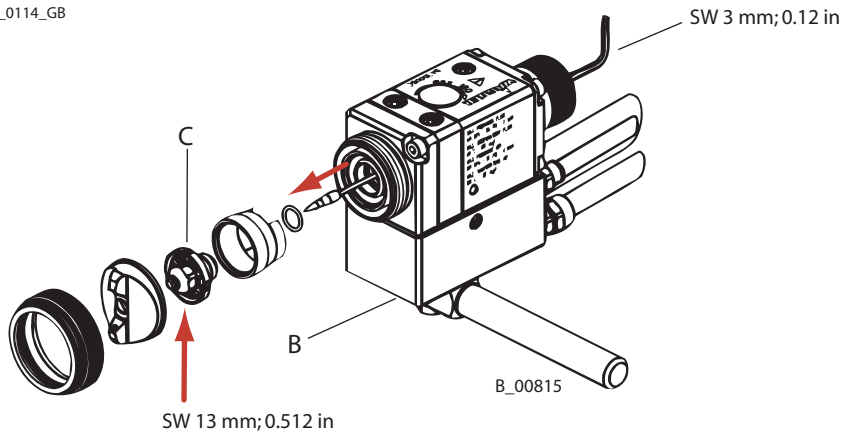

Note:
Circulation mode without pin

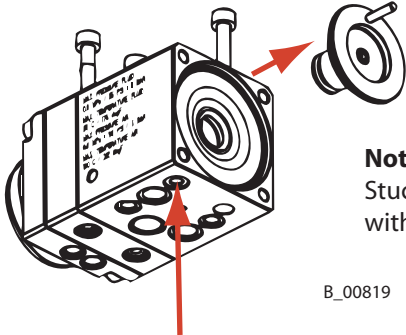

Note:
Stuck components can be pushed out with a drift \varnothing 3 mm; 0.12 inch.

B_00819

Blow gun

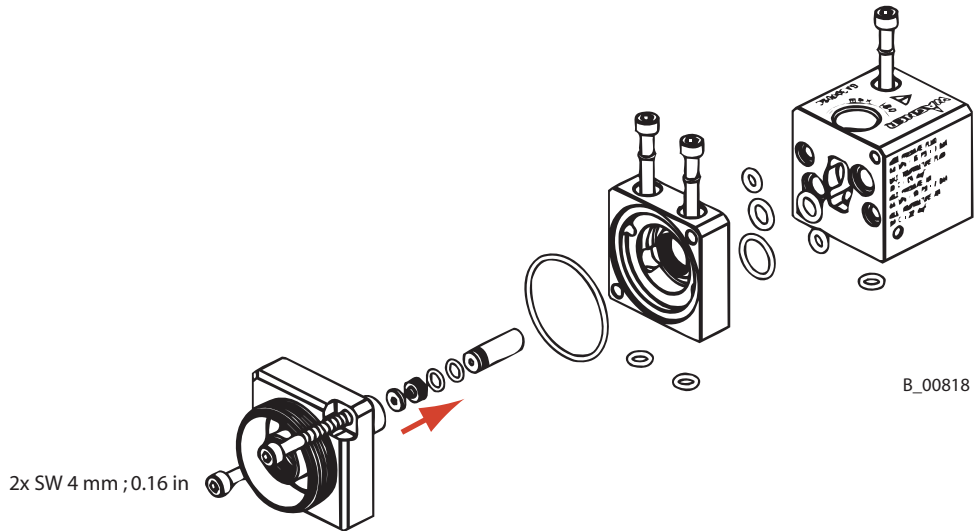

2x SW 4 mm ; 0.16 in

B_00818

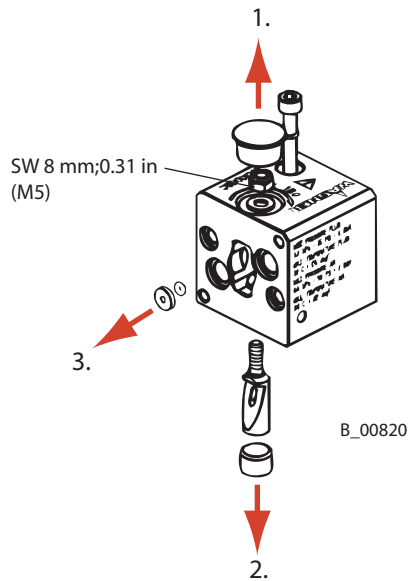

SW 8 mm; 0.31 in (M5)

B_00820

6.4 REPLACING PARTS IN THE VALVE TAPPET

1. Cut carefully the faulty parts (B) and / or (D) with a sharp knife and remove its.
2. Unscrew threaded pin (G) using allen wrench 3 mm; 0.12 inch and remove clamping tongs (F).
3. Replace defective parts.
4. Reassemble in reverse order

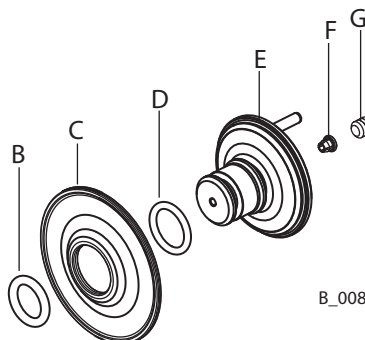

B_00845

Note

Threaded pin (G) not tighten.

CAUTION**Damage to the sliding surfaces using tools!**

Destruction of the O-rings and the diaphragm while replacing. Malfunction

→ Handle sliding surfaces with care, do not damage.

SIHL_0115_GB

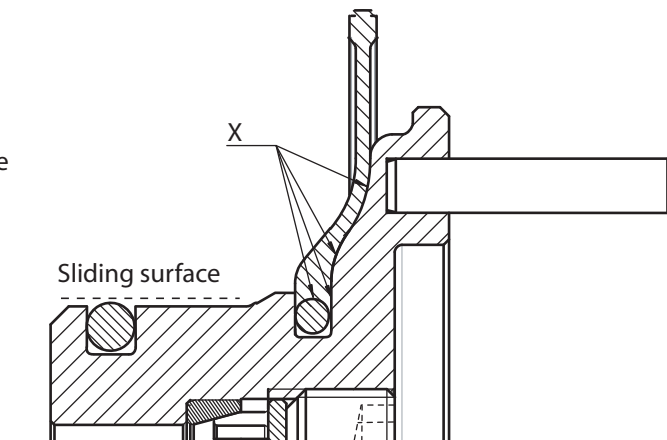
Note XLightly greased with Vaseline
PHHV II Part No. 9992698

B_00846

6.5 REASSEMBLING

	WARNING
	<p>The plug (P) is under high pressure! The plug can fly off like a projectile</p> <p>→ In NC mode (without material circulation), connect the gun only with the closing pin (O) fitted.</p>

SIHI_0007_GB

Note:
Apply only the nut (M5), not tighten.

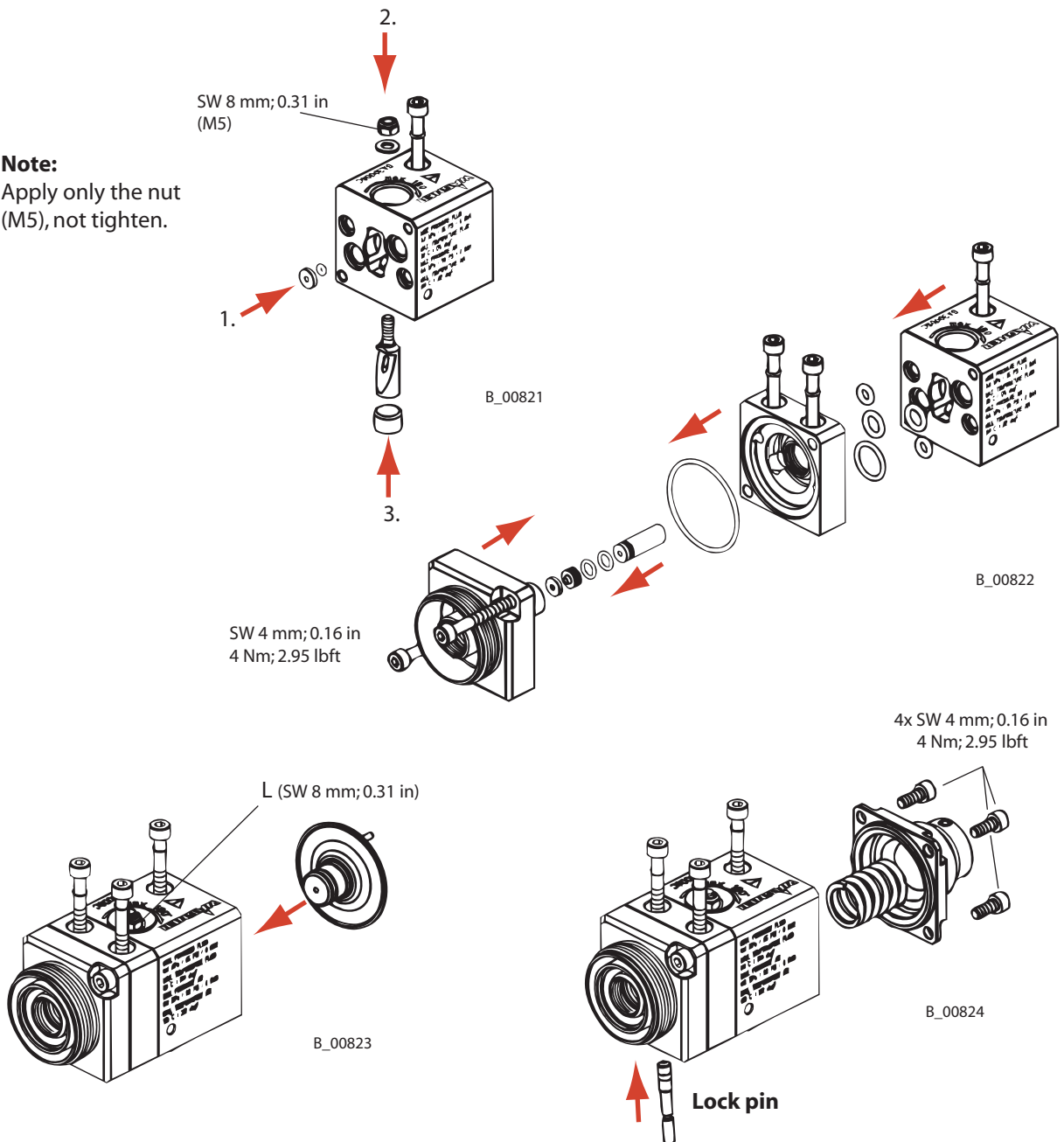

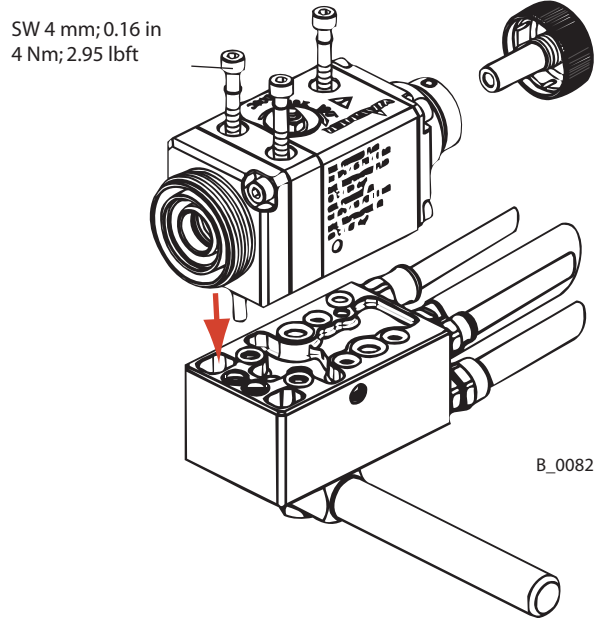

Note:
Tighten nut (L), that the valve tappet (A) is still easily adjustable.

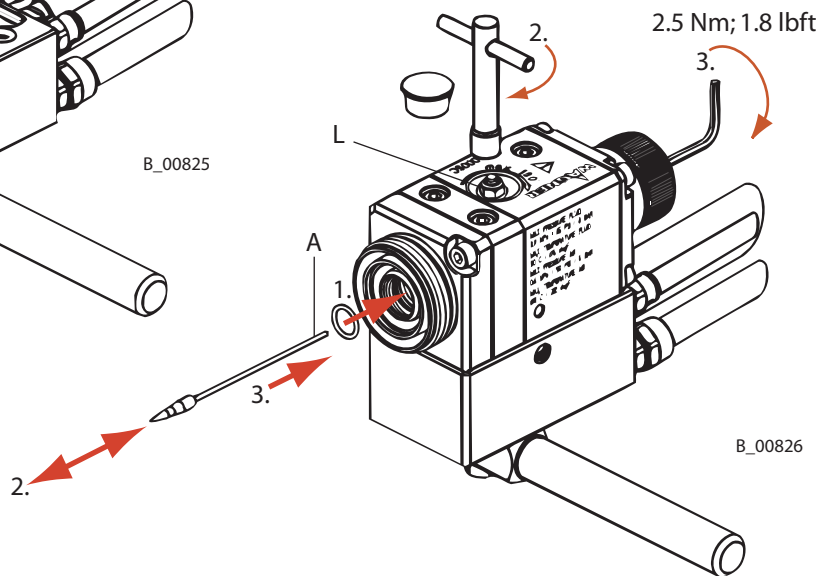

CAUTION

Strong friction between valve needle and nozzle while unscrewing!
Damage to the sealing surfaces

→ Always turn on the control air before screwing in/unscrewing the nozzle (C).

SIHI_0114_GB

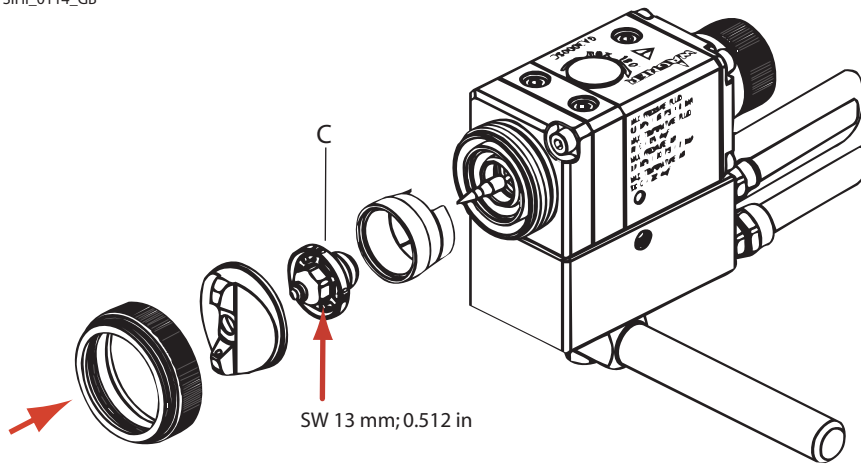

7 TROUBLESHOOTING AND SOLUTIONS

Problem	Cause	Solution
Insufficient material output	• Nozzle too small	• Select larger nozzle (see chapter 9)
	• Material pressure too low	• Increase material pressure
	• Nozzle is clogged	• Nozzle cleaning (see chapter 5)
	• Valve stem defective	• Increase the control air pressure Replace valve rod
Poor spray pattern	• Wrongly adjusted atomizing air	• Readjust the atomizing air (see chapter 5)
	• Nozzle too large	• Select smaller nozzle (see chapter 9)
	• Material pressure too low	• Increase material pressure
	• Material viscosity too high	• Thin material in accordance with the manufacturer's instructions
	• Wrongly adjusted shaping air	• Readjust shaping air
	• Air cap faulty (blocked holes, damaged seal)	• Clean or replace air cap
Packing leaks	• Pretension too low	• Tighten the clamping wedge (maxi. 180°)
Spray gun will not shut-off correctly / Material valve leaks	• Receiver valve seat or valve needle damage	• Replace parts
	• Packing-screw too tight, or packing stuck with dried paint	• Loosen clamping wedge and press it downward.

If the problem is not listed above consult your WAGNER Service Center.

8 ACCESSORIES

8.1 AIR CAPS

Part No.	Description	Type
383920	Air cap SC3000	2.00
383921	Air cap SC3000	2.50
383922	Air cap SC3000	3.15
383923	Air cap SC3000	4.00



B_00788



B_00789



B_00791



B_00790

8.2 NOZZLES

Part No.	Description
383937	Nozzle SC3000 0.30 Set
383930	Nozzle SC3000 0.50 Set
383931	Nozzle SC3000 0.80 Set
383932	Nozzle SC3000 1.00 Set
383933	Nozzle SC3000 1.25 Set
383934	Nozzle SC3000 1.60 Set
383935	Nozzle SC3000 2.00 Set
383936	Nozzle SC3000 2.50 Set

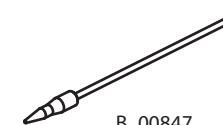

B_00847



B_00793

The following nozzle sizes are available also as option with Balinit coating. These nozzles can be referred only in 10er packs.

2306387	Nozzle SC3000 1.25 Set B (with 10 pieces)
2306389	Nozzle SC3000 1.6 Set B (with 10 pieces)

8.2.1 OUTPUT MEASURED WITH WATER H₂O

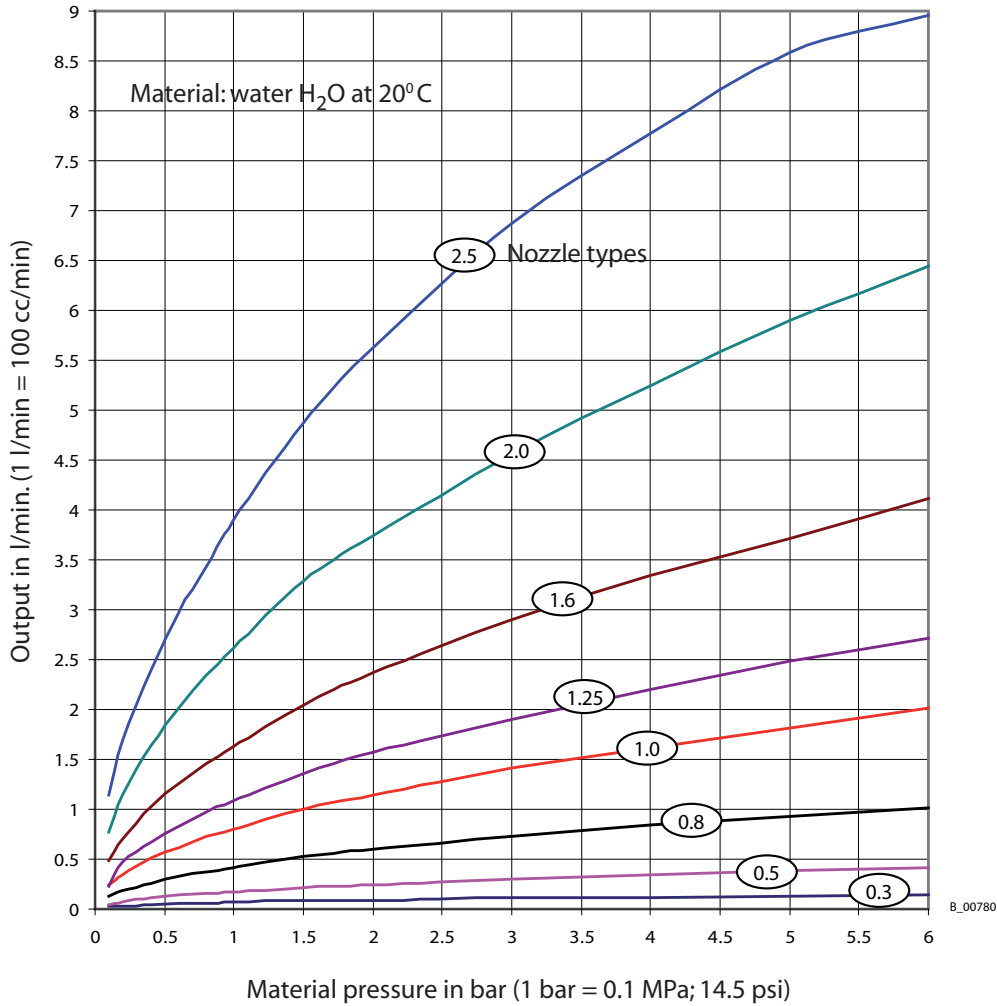

8.3 CONNECTIONS

8.3.1 MATERIAL

With material circulation 2 material connections are needed, otherwise only one.

Part No.	Description
9999205	Straight threaded fitting, G1/4" to D6 mm; AD 0.24 inch
9999162	Straight threaded fitting, G1/4" to D8 mm; AD 5/16"
9998649	Straight threaded fitting, G1/4" to D10 mm; AD 0.39 inch
9998958	Straight threaded fitting, G1/8" to D8 mm; AD 0.31 inch
9998650	Straight threaded fitting, G1/8" to D10 mm; AD 0.39 inch



8.3.1.1 KINK PROTECTION FOR MATERIAL CONNECTIONS

Part No.	Description
9999206	Union nut with anti kink, fits to part no. 9999205
9998959	Union nut with anti kink, fits to part no. 9999162
9999165	Union nut with anti kink, fits to part no. 9999163

8.3.2 ATOMIZING AIR

Part No.	Description
383960	Connecting set C d19; ID 0.75 inch, includes part no. 9998098
383961	Connecting set M24x1.5 - d19; ID 0.75 inch, includes part no 9998098



8.3.3 ATOMIZING AIR/ SHAPING AIR

In delivery scope of the gun a straight threaded fitting D6 mm/ d4 mm; AD 0.24 inch/ ID 0.16 inch is contained.

Part-No.	Description
9998993	Straight threaded fitting, G 1/8"; D8 mm/ d6 mm; AD 0.31 inch/ ID 0.24 inch



8.4 MATERIAL CIRCULATION

If you do not need material circulation, a sealing pin will be required.

Part No.	Description
380923	Lock pin assy
380963	Lock pin assy UV



8.5 MISCELLANEOUS

Part No.	Description
380940	Standard gun holder 120 mm, Ø 16 mm; 4.72 inch, Ø 0.63 inch
380941	Standard gun holder 180 mm, Ø 16 mm; 7.1 inch, Ø 0.63 inch
380942	Holder rotary
380943	Swivel drive assy.
380944	Cross attaching piece for swivel drive
383170	Air valve (stand alone)

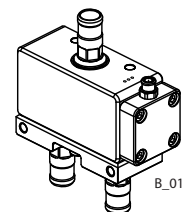
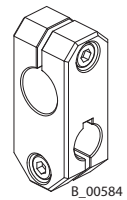
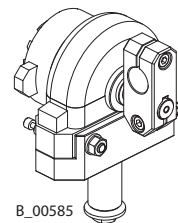
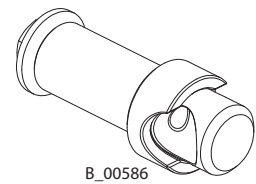
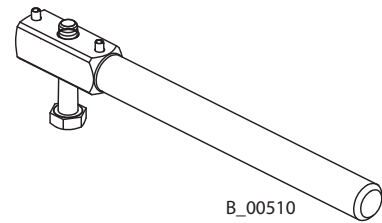
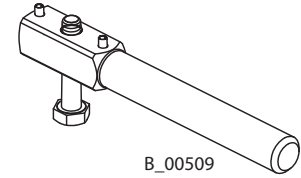

Part No.	Description
383165	Thermal separating plate
383186	Dump valve assy. 1/8"
383160	Air cap positioning unit
383983	Conversion set GA 3000SCEC UV (After the change with the conversion set in principle the gun also allows UV lacquers to be used)

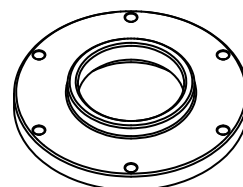

B_01279

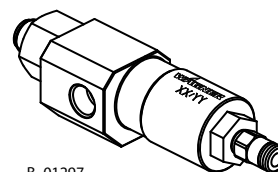

B_01297

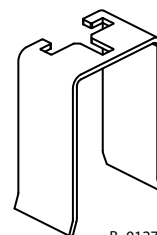

B_01278

9 SPARE PARTS CATALOGUE

9.1 HOW TO ORDER SPARE PARTS?

Always supply the following information to ensure delivery of the right spare part:

Part Number, description and quantity

The quantity need not be the same as the number given in the „Quantity“ column. This number merely indicates how many of the respective parts are used in each subassembly.



The following information is also required to ensure smooth processing of your order:

- Address for the invoice
- Address for delivery
- Name of the person to be contacted in the event of any queries
- Type of delivery required (air freight or mail, sea route or overland route, etc.)

Marks in spare parts lists

Note to column „K“ in the following spare parts lists.

- ◆ = Wearing parts
Note: No liability is assumed for wearing parts
- = Not part of standard equipment, available, however, as additional extra.

	 WARNING
	<p>Incorrect maintenance/repair! Risk of injury and damage to the equipment</p> <ul style="list-style-type: none"> → Repairs and part replacement may only be carried out by specially trained staff or a WAGNER service center. → Before all work on the unit and in the event of work interruptions: <ul style="list-style-type: none"> - Switch off the energy/compressed air supply. - Relieve the pressure from the spray gun and unit. - Secure the spray gun against actuation. → Observe the operating and service instructions when carrying out all work.

SIHL_0004_GB

9.2 SPARE PARTS LIST GA 3000SCEC

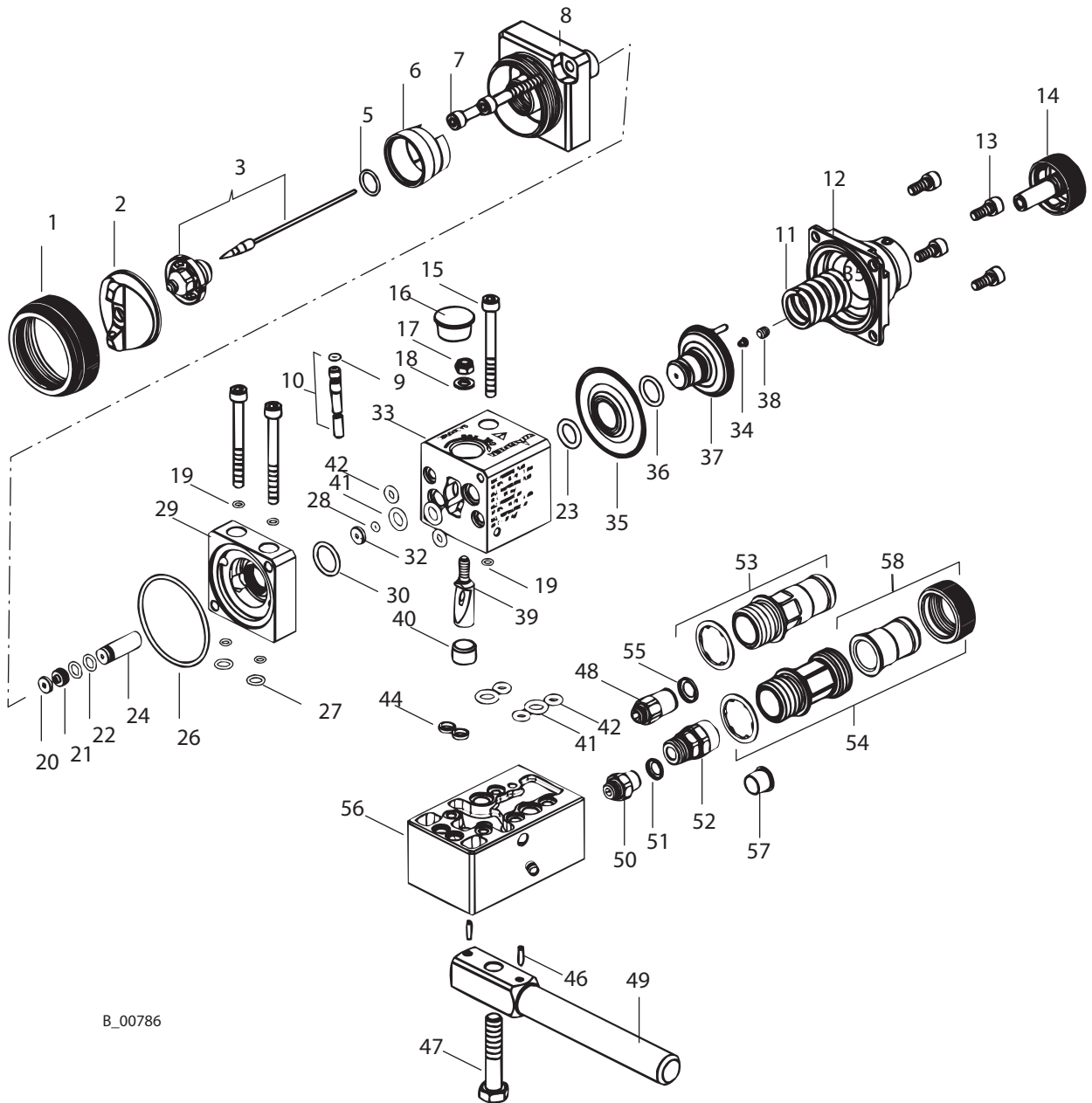

B_00786

Spare parts list GA 3000SCEC				
Item	K	Qty	Part No.	Description
1		1	364302	Union nut
2	●	1	383...	Air cap SC3000 (see chapter 8)
3	◆	1	383...	Nozzle SC3000 x.xx Set (see chapter 8)
5	◆	1	380309	O-ring
6		1	383306	Distributor air
7		2	9907225	Cap head screw
8		1	383404	Gun head EC
9	◆	1	9971383	O-ring
10	●	1	380923	Lock pin assy.
11		1	9998991	Pressure spring
12		1	383940	Jam sleeve assy.
13		4	9907191	Cap head screw
14		1	383941	Throttle screw material assy.
15		3	9907193	Cap head screw
16		1	9990623	Plug
17		1	9913046	Self-locking hexagon nuts
18		1	9920101	Washer
19	◆	5	9971182	O-ring
20		1	380310	Support piece
21	◆	1	380311	Gasket
22	◆	2	9971379	O-ring
23	◆	1	9974149	O-ring
24		1	383403	Thrust piece EC
26	◆	1	9974174	O-ring
27	◆	2	9974066	O-ring
28	◆	1	9971382	O-ring
29		1	383302	Spacer IC
30	◆	1	9974166	O-ring
32		1	380314	Support disk
33		1	383400	Gun body EC
34		1	383314	Clamping tongs
35	◆	1	380306	Diaphragm
36	◆	1	9971313	O-ring

◆ = Wearing part

● = Not part of standard equipment for spray gun. Available, however, as additional extra

Note:

Information for spare part assemblies and for contents of service sets see chapter 9.9

Spare parts list GA 3000SCEC				
Item	K	Qty	Part No.	Description
37	◆	1	383942	Valve tappet premounted
38		1	9907230	Set screw
39		1	380313	Clamping wedge
40		1	9955812	Protection cap
41	◆	4	9971172	O-ring
42	◆	5	9974148	O-ring
44	◆	2	380321	Seal material
46	●	2	9935063	Pin
47	●	1	9900241	Hex bolt M8x40
48		1	9998993	Straight threaded fitting
49	●	1	380940	Clamp rod 120 mm; 4.72 inch
49	●	1	380941	Clamp rod 180 mm; 7.1 inch
50	●	1	9998090	Straight threaded fitting
51	●	1	9998995	Coding ring red
52	●	1	9999205	Straight threaded fitting G1/4" to D6 mm; 0.24 inch
52	●	1	9999162	Straight threaded fitting G1/4" to D8 mm; 0.31 inch
52	●	1	9998649	Straight threaded fitting G1/4" to D10 mm; 0.39 inch
53	●	1	383960	Connecting set C d19; ID 0.75 inch
54	●	1	383961	Connecting set C M24x1.5, d19; ID 0.75 inch
55	◆	1	9998616	Coding ring green
56		1	383401	Base plate EC
57		1	9998529	Protection cap
58	●	1	383962	Hose nozzle assy. M24x1.5, d19; ID 0.75 inch

◆ = Wearing part

● = Not part of standard equipment for spray gun. Available, however, as additional extra

Note:

Information for spare part assemblies and for contents of service sets see chapter 9.9

9.3 SPARE PARTS LIST GA 3000SCEC UV

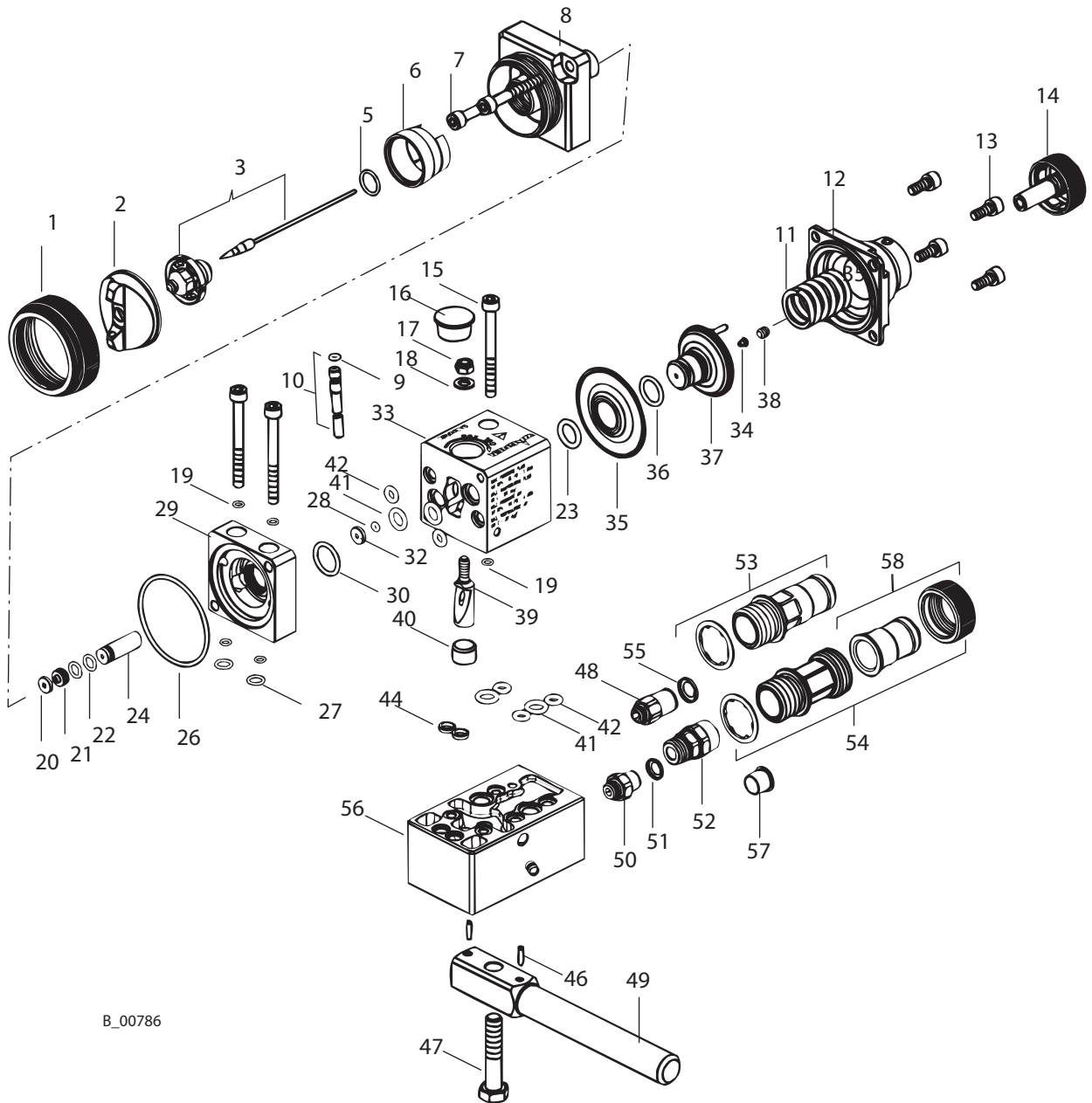

B_00786

Spare parts list GA 3000SCEC UV			
Item	K	Qty	Part No. Description
1		1	364302 Union nut
2	●	1	383... Air cap SC3000 (see chapter 8)
3	◆	1	383... Nozzle SC3000 x.xx Set (see chapter 8)
5	◆	1	380309 O-ring
6		1	383306 Distributor air
7		2	9907225 Cap head screw
8		1	383404 Gun head EC
9	◆	1	9974178 O-ring EPDM
10	●	1	380963 Lock pin assy. UV
11		1	9998991 Pressure spring
12		1	383940 Jam sleeve assy.
13		4	9907191 Cap head screw
14		1	383941 Throttle screw material assy.
15		3	9907193 Cap head screw
16		1	9990623 Plug
17		1	9913046 Self-locking hexagon nuts
18		1	9920101 Washer
19	◆	5	9974209 O-ring EPDM
20		1	380310 Support piece
21	◆	1	380322 Gasket UV
22	◆	2	9974179 O-ring
23	◆	1	9974149 O-ring
24		1	383405 Thrust piece SCEC UV
26	◆	1	9974215 O-ring EPDM
27	◆	2	9974210 O-ring EPDM
28	◆	1	9974208 O-ring EPDM
29		1	383402 Spacer EC
30	◆	1	9974213 O-ring EPDM
32		1	380314 Support disk
33		1	383400 Gun body EC
34		1	383314 Clamping tongs
35	◆	1	380306 Diaphragm
36	◆	1	9971313 O-ring

◆ = Wearing part

● = Not part of standard equipment for spray gun. Available, however, as additional extra

Note:

Information for spare part assemblies and for contents of service sets see chapter 9.9

Spare parts list GA 3000SCEC UV				
Item	K	Qty	Part No.	Description
37	◆	1	383942	Valve tappet premounted
38		1	9907230	Threaded pin
39		1	380313	Clamping wedge
40		1	9955812	Protection cap
41	◆	4	9974196	O-ring EPDM
42	◆	5	9974176	O-ring EPDM
44	◆	2	380321	Seal material
46	●	2	9935063	Pin
47	●	1	9900241	Hex bolt M8x40
48		1	9998993	Straight threaded fitting
49	●	1	380940	Clamp rod 120 mm; 4.72 inch
49	●	1	380941	Clamp rod 180 mm; 7.1 inch
50	●	1	9998090	Straight threaded fitting
51	●	1	9998995	Coding ring red
52	●	1	9999205	Straight threaded fitting G1/4" to D6 mm; 0.24 inch
52	●	1	9999162	Straight threaded fitting G1/4" to D8 mm; 0.31 inch
52	●	1	9998649	Straight threaded fitting G1/4" to D10 mm; 0.39 inch
53	●	1	383960	Connecting set C d19; ID 0.75 inch
54	●	1	383961	Connecting set C M24x1.5, d19; ID 0.75 inch
55	◆	1	9998616	Coding ring green
56		1	383917	Base plate EC UV
57		1	9998529	Protection cap
58	●	1	383962	Hose nozzle assy. M24x1.5, d19; ID 0.75 inch

◆ = Wearing part

● = Not part of standard equipment for spray gun. Available, however, as additional extra

Note:

Information for spare part assemblies and for contents of service sets see chapter 9.9

9.4 SPARE PARTS LIST GA 3000SCEC ROBOT

Spare parts list GA 3000SCEC Robot (for FANUC)			
Item	K	Qty	Part No. Description
1		1	364302 Union nut
2	●	1	383... Air cap SC3000 (see chapter 8)
3	◆	1	383... Nozzle SC3000 x.xx Set (see chapter 8)
5	◆	1	380309 O-ring
6		1	383306 Distributor air
7		2	9907225 Cap head screw
8		1	383404 Gun head EC
9	◆	1	9971383 O-ring
10	●	1	380923 Lock pin assy.
11		1	9998991 Pressure spring
12		1	383940 Jam sleeve assy.
13		4	9907191 Cap head screw
14		1	383941 Throttle screw material assy.
15		3	9907193 Cap head screw
16		1	9990623 Plug
17		1	9913046 Self-locking hexagon nuts
18		1	9920101 Washer
19	◆	5	9971182 O-ring
20		1	380310 Support piece
21	◆	1	380311 Gasket
22	◆	2	9971379 O-ring
23	◆	1	9974149 O-ring
24		1	383403 Thrust piece EC
26	◆	1	9974174 O-ring
27	◆	2	9974066 O-ring
28	◆	1	9971382 O-ring
29		1	383302 Spacer EC
30	◆	1	9974166 O-ring
32		1	380314 Support disk
33		1	383400 Gun body EC
34		1	383314 Clamping tongs
35	◆	1	380306 Diaphragm

◆ = Wearing part

● = Not part of standard equipment for spray gun. Available, however, as additional extra

Note:

Information for spare part assemblies and for contents of service sets see chapter 9.9

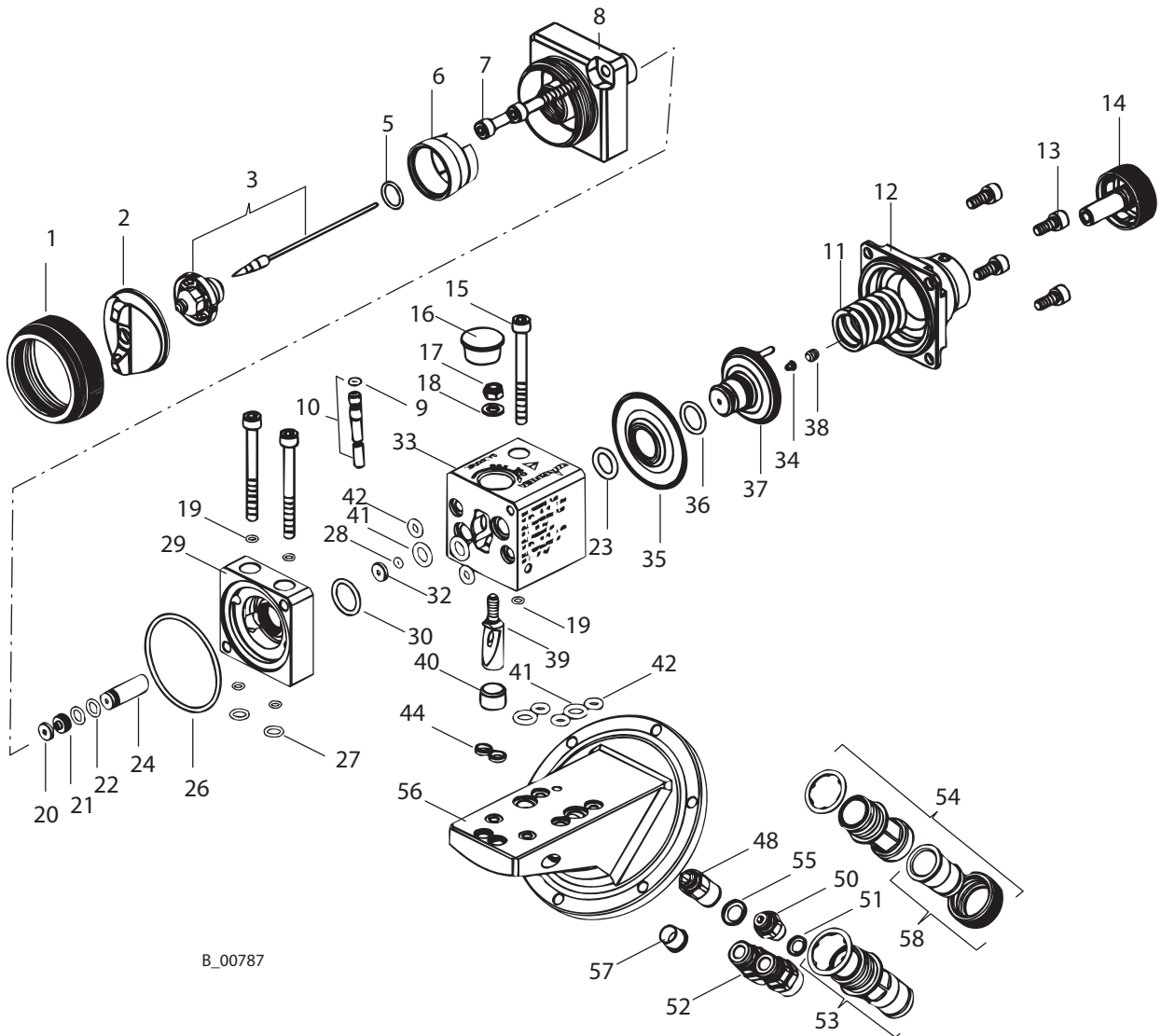

B_00787

Spare parts list GA 3000SCEC Robot (for FANUC)				
Item	K	Qty	Part No.	Description
36	◆	1	9971313	O-ring
37	◆	1	383942	Valve tappet premounted
38		1	9907230	Set screw
39		1	380313	Clamping wedge
40		1	9955812	Protection cap
41	◆	4	9971172	O-ring
42	◆	5	9974148	O-ring
44	◆	2	380321	Seal material
48		1	9998993	Straight threaded fitting
50	●	1	9998090	Straight threaded fitting
51	●	1	9998995	Coding ring red
52	●	1	9999205	Straight threaded fitting G1/4" to D6 mm; 0.24 inch
52	●	1	9999162	Straight threaded fitting G1/4" to D8 mm; 0.31 inch
52	●	1	9998649	Straight threaded fitting G1/4" to D10 mm; 0.39 inch
53	●	1	383960	Connecting set C d19; ID 0.75 inch
54	●	1	383961	Connecting set C M24x1.5, d19; ID 0.75 inch
55	◆	1	9998616	Coding ring green
56		1	383299	Base plate EC Robot
57		1	9998529	Protection cap
58	●	1	383962	Hose nozzle assy. M24x1.5, d19; ID 0.75 inch

◆ = Wearing part

● = Not part of standard equipment for spray gun. Available, however, as additional extra

Note:

Information for spare part assemblies and for contents of service sets see chapter 9.9

9.5 SPARE PARTS LIST GA 3000SCEC ROBOT UV

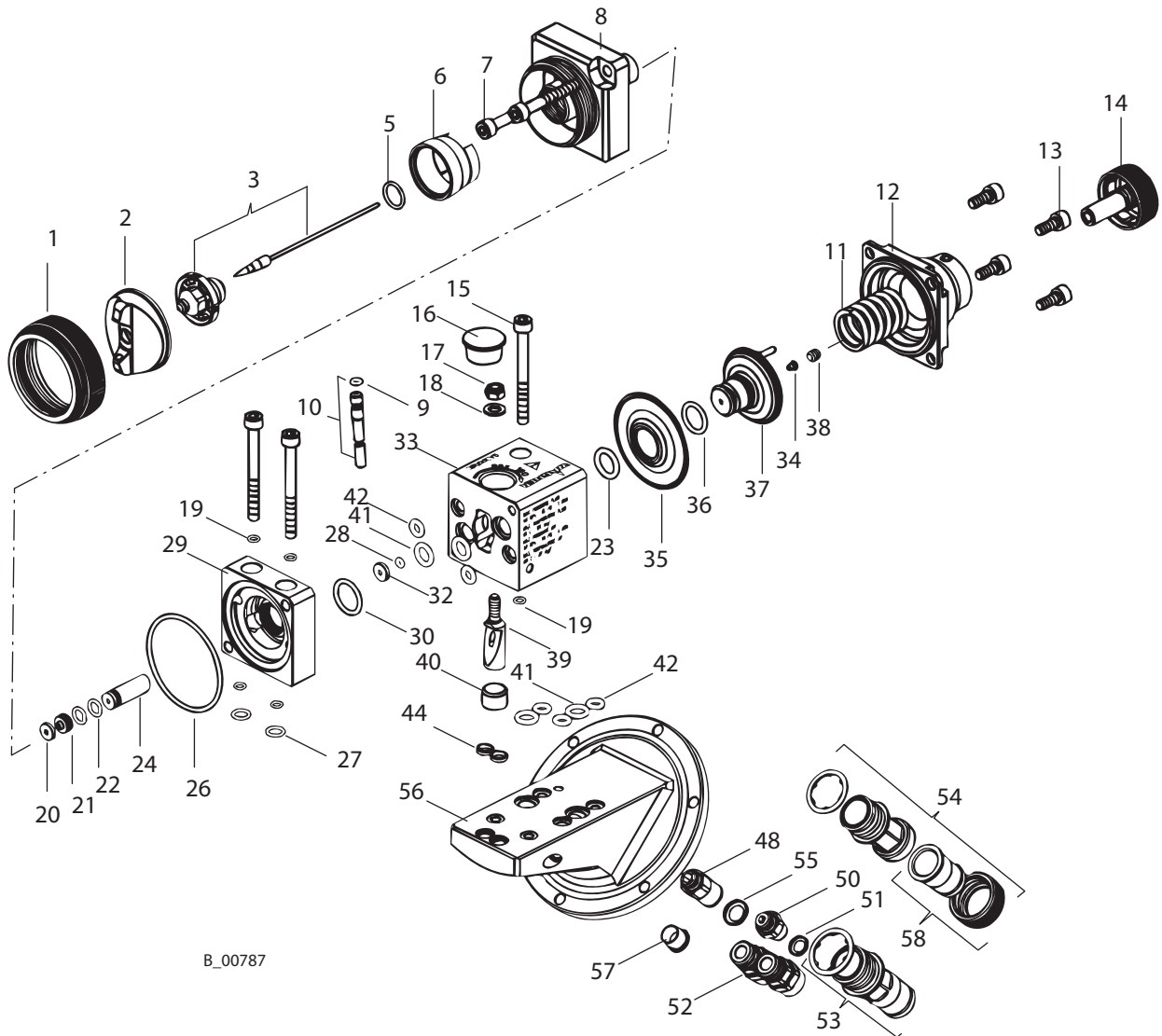

B_00787

Spare parts list GA 3000SCEC Robot UV (for FANUC)			
Item K	Qty	Part No.	Description
1	1	364302	Union nut
2 ●	1	383...	Air cap SC3000 (see chapter 8)
3 ◆	1	383...	Nozzle SC3000 x.xx Set (see chapter 8)
5 ◆	1	380309	O-ring
6	1	383306	Distributor air
7	2	9907225	Cap head screw
8	1	383404	Gun head EC
9 ◆	1	9974178	O-ring EPDM
10 ●	1	380963	Lock pin assy. UV
11	1	9998991	Pressure spring
12	1	383940	Jam sleeve assy.
13	4	9907191	Cap head screw
14	1	383941	Throttle screw material assy.
15	3	9907193	Cap head screw
16	1	9990623	Plug
17	1	9913046	Self-locking hexagon nuts
18	1	9920101	Washer
19 ◆	5	9974209	O-ring EPDM
20	1	380310	Support piece
21 ◆	1	380322	Gasket UV
22 ◆	2	9974179	O-ring EPDM
23 ◆	1	9974149	O-ring
24	1	383405	Thrust piece SCEC UV
26 ◆	1	9974215	O-ring EPDM
27 ◆	2	9974210	O-ring EPDM
28 ◆	1	9974208	O-ring EPDM
29	1	383402	Spacer EC
30 ◆	1	9974213	O-ring
32	1	380314	Support disk
33	1	383400	Gun body EC
34	1	383314	Clamping tongs
35 ◆	1	380306	Diaphragm
36 ◆	1	9971313	O-ring
37 ◆	1	383942	Valve tappet premounted

◆ = Wearing part

● = Not part of standard equipment for spray gun. Available, however, as additional extra

Note:

Information for spare part assemblies and for contents of service sets see chapter 9.9

Spare parts list GA 3000SCEC Robot UV (for FANUC)			
Item K	Qty	Part No.	Description
38	1	9907230	Set screw
39	1	380313	Clamp wedge
40	1	9955812	Protection cap
41	◆	9974196	O-ring EPDM
42	◆	9974176	O-ring EPDM
44	◆	380321	Seal material
48	1	9998993	Straight threaded fitting
50	●	9998090	Straight threaded fitting
51	●	9998995	Coding ring red
52	●	9999205	Straight threaded fitting G1/4" to D6 mm; 0.24 inch
52	●	9999162	Straight threaded fitting G1/4" to D8 mm; 0.31 inch
52	●	9998649	Straight threaded fitting G1/4" to D10 mm; 0.39 inch
53	●	383960	Connecting set C d19; ID 0.75 inch
54	●	383961	Connecting set C M24x1.5, d19; ID 0.75 inch
55	◆	9998616	Coding ring green
56	1	383299	Base plate EC Robot
57	1	9998529	Protection cap
58	●	383962	Hose nozzle assy. M24x1.5, d19; ID 0.75 inch

◆ = Wearing part

● = Not part of standard equipment for spray gun. Available, however, as additional extra

Note:

Information for spare part assemblies and for contents of service sets see chapter 9.9

9.6 SPARE PARTS LIST GA 3000SCEC ROBOT TWIN

Spare parts list GA 3000SCEC Robot Twin			
Item	K	Qty	Part No. Description
1		1	364302 Union nut
2	●	1	383... Air cap SC3000 (see chapter 8)
3	◆	1	383... Nozzle SC3000 x.xx Set (see chapter 8)
5	◆	1	380309 O-ring
6		1	383306 Distributor air
7		2	9907225 Cap head screw
8		1	383404 Gun head EC
9	◆	1	9971383 O-ring
10	●	1	380923 Lock pin assy.
11		1	9998991 Pressure spring
12		1	383940 Jam sleeve assy.
13		4	9907191 Cap head screw
14		1	383941 Throttle screw material assy.
15		3	9907193 Cap head screw
16		1	9990623 Plug
17		1	9913046 Self-locking hexagon nuts
18		1	9920101 Washer
19	◆	5	9971182 O-ring
20		1	380310 Support piece
21	◆	1	380311 Gasket
22	◆	2	9971379 O-ring
23	◆	1	9974149 O-ring
24		1	383403 Thrust piece EC
26	◆	1	9974174 O-ring
27	◆	2	9974066 O-ring
28	◆	1	9971382 O-ring
29		1	383402 Spacer EC
30	◆	1	9974166 O-ring
32		1	380314 Support disk
33		1	383400 Gun body EC
34		1	383314 Collet chuck
35	◆	1	380306 Diaphragm

◆ = Wearing part

● = Not part of standard equipment for spray gun. Available, however, as additional extra

Note:

Information for spare part assemblies and for contents of service sets see chapter 9.9
The quantities of Items 1 to 40 only apply for 1 gun.

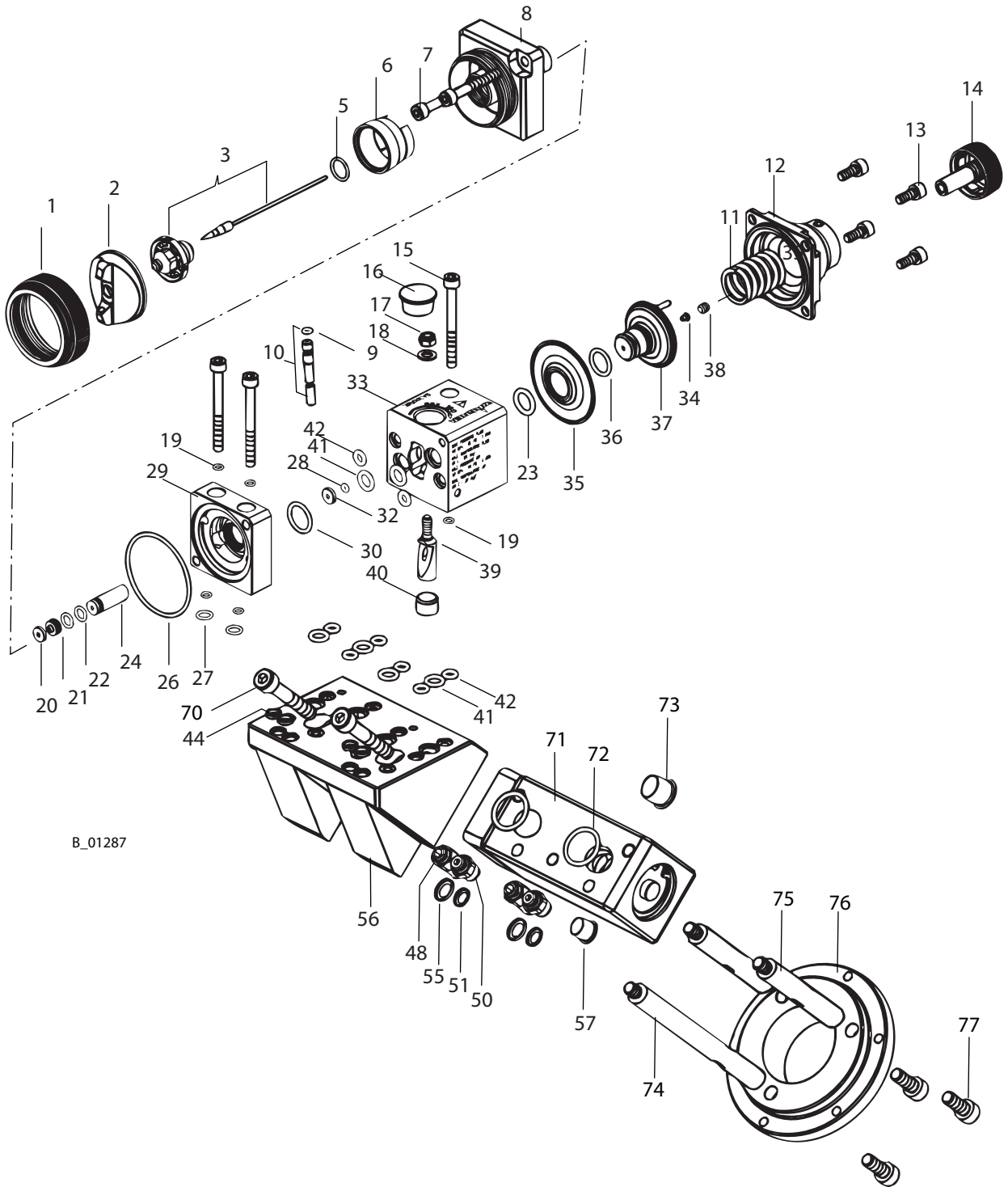

B_01287

Spare parts list GA 3000SCEC Robot Twin				
Item	K	Qty	Part No.	Description
36	◆	1	9971313	O-ring
37	◆	1	383942	Valve tappet premounted
38		1	9907230	Set screw
39		1	380313	Clamp wedge
40		1	9955812	Protection cap
41	◆	4	9974196	O-ring
42	◆	5	9974176	O-ring
44	◆	2	380321	Seal material
48		2	9998993	Straight threaded fitting
50	●	2	9998090	Straight threaded fitting
51	●	2	9998995	Coding ring red
55	◆	1	9998616	Coding ring green
56	◆	1	383605	Base plate SC EC Robot Twin
57		4	9999385	Protection cap
70		2	9907251	Cap head screw M8x50
71	◆	1	383995	Air valve assy.
72	◆	2	9971346	O-ring
73		1	9999168	Protection cap
74		1	383601	Distance pin
75		2	383602	Distance pin
76		1	383604	Adapter Fanuc Robot
77		3	9906031	Cap head screw M8x20

◆ = Wearing part

● = Not part of standard equipment for spray gun. Available, however, as additional extra

Note:

Information for spare part assemblies and for contents of service sets see chapter 9.9

The quantities of Items 1 to 40 only apply for 1 gun.

9.7 SPARE PARTS LIST GA 3000SCEC ROBOT TWIN UV

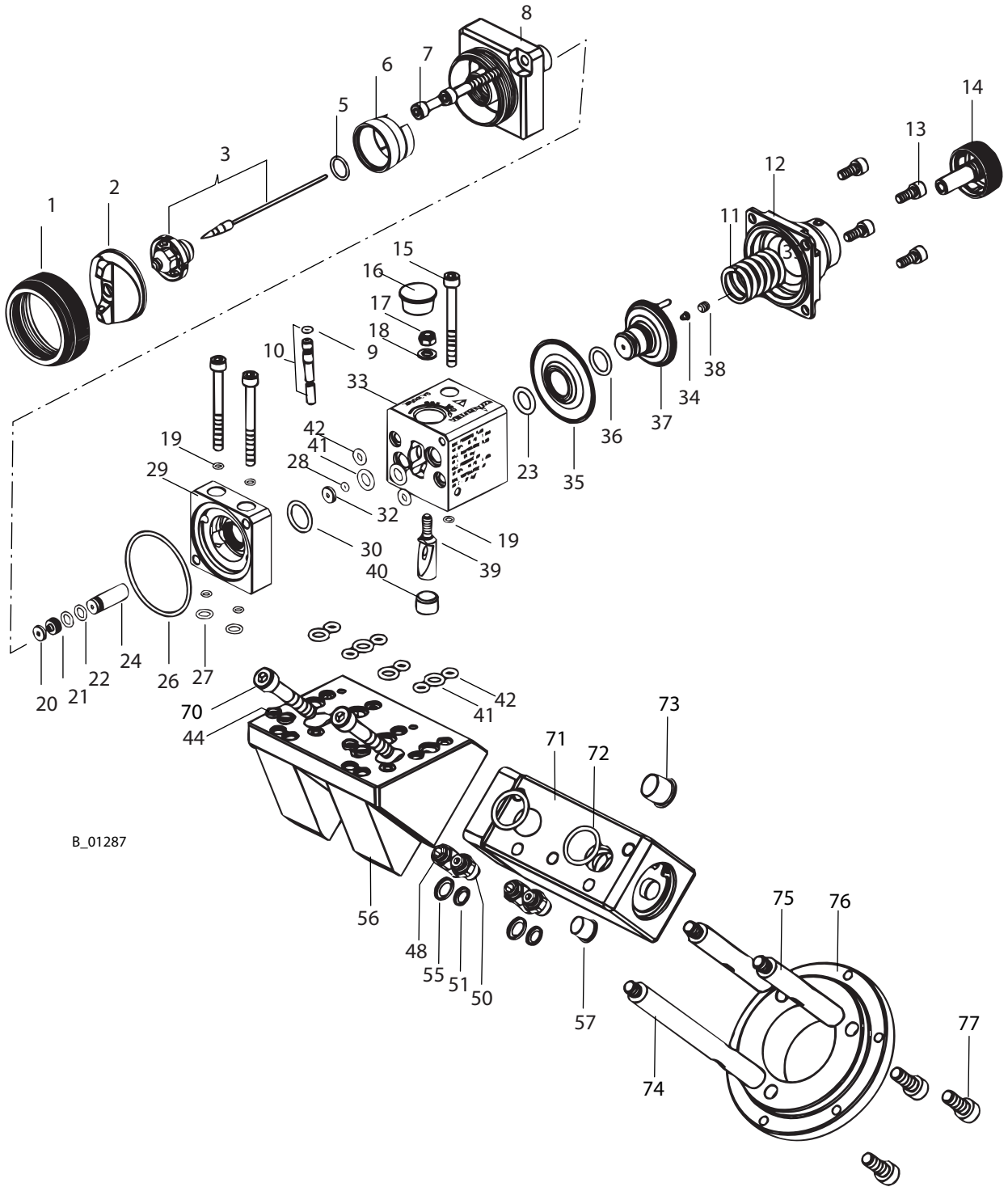

B_01287

Spare parts list GA 3000SCEC Robot Twin UV				
Item	K	Qty	Part No.	Description
1		1	364302	Union nut
2	●	1	383...	Air cap SC3000 (see chapter 8)
3	◆	1	383...	Nozzle SC3000 x.xx Set (see chapter 8)
5	◆	1	380309	O-ring
6		1	383306	Distributor air
7		2	9907225	Cap head screw
8		1	383404	Gun head EC
9	◆	1	9974178	O-ring EPDM
10	●	1	380963	Lock pin assy. UV
11		1	9998991	Pressure spring
12		1	383940	Jam sleeve assy.
13		4	9907191	Cap head screw
14		1	383941	Throttle screw material assy.
15		3	9907193	Cap head screw
16		1	9990623	Plug
17		1	9913046	Self-locking hexagon nuts
18		1	9920101	Washer
19	◆	5	9974209	O-ring EPDM
20		1	380310	Support piece
21	◆	1	380322	Gasket UV
22	◆	2	9974179	O-ring EPDM
23	◆	1	9974149	O-ring
24		1	383405	Thrust piece SCEC UV
26	◆	1	9974215	O-ring EPDM
27	◆	2	9974210	O-ring EPDM
28	◆	1	9974208	O-ring EPDM
29		1	383402	Spacer EC
30	◆	1	9974213	O-ring EPDM
32		1	380314	Support disk
33		1	383400	Gun body EC
34		1	383314	Collet chuck
35	◆	1	380306	Diaphragm
36	◆	1	9971313	O-ring

◆ = Wearing part

● = Not part of standard equipment for spray gun. Available, however, as additional extra

Note:

Information for spare part assemblies and for contents of service sets see chapter 9.9
The quantities of Items 1 to 40 only apply for 1 gun.

Spare parts list GA 3000SCEC Robot Twin UV				
Item	K	Qty	Part No.	Description
37	◆	1	383942	Valve tappet premounted
38		1	9907230	Set screw
39		1	380313	Taper key
40		1	9955812	Protection cap
41	◆	4	9974196	O-ring EPDM
42	◆	5	9974176	O-ring EPDM
44	◆	2	380321	Seal material
48		2	9998993	Straight threaded fitting
50	●	2	9998090	Straight threaded fitting
51	●	2	9998995	Coding ring red
55	◆	1	9998616	Coding ring green
56	◆	1	383605	Base plate SC EC Robot Twin
57		4	9999385	Protection cap
70		2	9907251	Cap head screw M8x50
71	◆	1	383995	Air valve assy.
72	◆	2	9971346	O-ring
73		1	9999168	Protection cap
74		1	383601	Distance pin
75		2	383602	Distance pin
76		1	383604	Adapter Fanuc Robot
77		3	9906031	Cap head screw M8x20

◆ = Wearing part

● = Not part of standard equipment for spray gun. Available, however, as additional extra

Note:

Information for spare part assemblies and for contents of service sets see chapter 9.9

The quantities of Items 1 to 40 only apply for 1 gun.

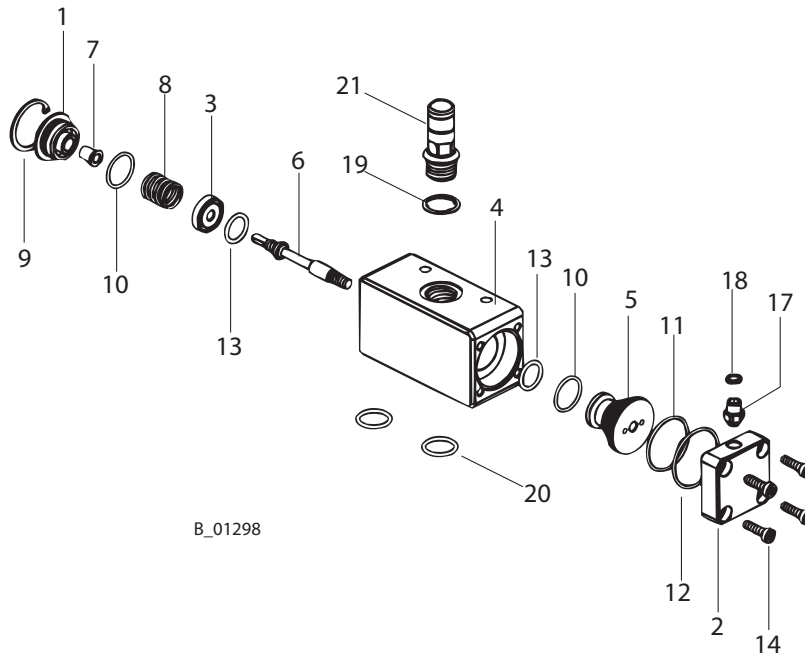
9.8 SPARE PARTS LIST AIR VALVE

Spare parts list air valve Part No. 383995			
Item K	Qty	Part No.	Description
1	1	383610	Cap
2	1	383611	Control cap
3	1	383612	Spring plate
4	1	383613	Valve housing
5	1	383614	Valve head
6	◆	383615	Valve stem
7	◆	383616	Bush
8	◆	383621	Pressure spring
9	1	9999360	Retaining ring
10	◆	9974216	O-ring
11	◆	9971405	O-ring
12	◆	9974168	O-ring
13	◆	9974205	O-ring
14	4	9902124	Hexagon socket head screw

◆ = Wearing part

● = Not part of standard equipment for spray gun. Available, however, as additional extra

Note:

Information for spare part assemblies and for contents of service sets see chapter 9.9

Spare parts list air valve Part No. 383995			
Item K	Qty	Part No.	Description
15	1	9992698	Vaseline white PPHV II
16	1	9992511	Loctite 243
17	1	9998090	Fitting straight
18	1	9998995	Coding ring red
19 ●	1	9970148	Seal ring
20 ◆	2	9971346	O-ring
21 ●	1	383350	Screw-in socket G1/2"A - d19; ID 0.75 inch

◆ = Wearing part

● = Not part of standard equipment for spray gun. Available, however, as additional extra

Note:

Information for spare part assemblies and for contents of service sets see chapter 9.9

9.9 OVERVIEW OF ASSEMBLIES

Part No.	Description	Consisting of spare parts positions, see spare part picture at chapter 9.2; 9.3; 9.4; 9.5; 9.6; 9.7 or 9.8.
383910	Gun body EC assy. 0.5	1, 3, 5, 6, 7, 8, 11, 12, 13, 14, 15, 16, 17, 18, 19, 20, 21, 22, 23, 24, 25, 26, 28, 29, 30, 32, 33, 34, 35, 36, 37, 38, 39, 40
383911	Gun body EC assy. 0.8	1, 3, 5, 6, 7, 8, 11, 12, 13, 14, 15, 16, 17, 18, 19, 20, 21, 22, 23, 24, 25, 26, 28, 29, 30, 32, 33, 34, 35, 36, 37, 38, 39, 40
383912	Gun body EC assy. 1.0	1, 3, 5, 6, 7, 8, 11, 12, 13, 14, 15, 16, 17, 18, 19, 20, 21, 22, 23, 24, 25, 26, 28, 29, 30, 32, 33, 34, 35, 36, 37, 38, 39, 40
383913	Gun body EC assy. 1.25	1, 3, 5, 6, 7, 8, 11, 12, 13, 14, 15, 16, 17, 18, 19, 20, 21, 22, 23, 24, 25, 26, 28, 29, 30, 32, 33, 34, 35, 36, 37, 38, 39, 40
383914	Gun body EC assy. 1.6	1, 3, 5, 6, 7, 8, 11, 12, 13, 14, 15, 16, 17, 18, 19, 20, 21, 22, 23, 24, 25, 26, 28, 29, 30, 32, 33, 34, 35, 36, 37, 38, 39, 40
383915	Gun body EC assy. 2.0	1, 3, 5, 6, 7, 8, 11, 12, 13, 14, 15, 16, 17, 18, 19, 20, 21, 22, 23, 24, 25, 26, 28, 29, 30, 32, 33, 34, 35, 36, 37, 38, 39, 40
383916	Gun body EC assy. 2.5	1, 3, 5, 6, 7, 8, 11, 12, 13, 14, 15, 16, 17, 18, 19, 20, 21, 22, 23, 24, 25, 26, 28, 29, 30, 32, 33, 34, 35, 36, 37, 38, 39, 40
383918	Base plate EC assy.	41, 42, 43, 44, 48, 50, 51, 56
383909	Valve tappet assy.	23, 34, 35, 36, 37, 38
383960	Connection set C d19; ID 0.75 inch	53
383961	Connection set C M24x1.5, d19; ID 0.75 inch	54
383975	Service set GA 3000SCEC	5, 19, 21, 22, 23, 26, 27, 28, 30, 34, 35, 36, 37, 38, 41, 42, 44,
383984	Service set GA 3000SCEC UV	5, 19, 21, 22, 23, 26, 27, 28, 30, 34, 35, 36, 37, 38, 41, 42, 44,
383976	Service set Gun body EC assy.	5, 19, 21, 22, 23, 26, 27, 28, 30, 34, 35, 36, 37, 38.55
383977	Service set Base plate EC assy.	41, 42, 44
383978	Service set Base plate SC Twin assy.	41, 42, 44,
383979	Service set Air valve	10, 11, 12, 13, 20

<p>Germany J. WAGNER GmbH Otto-Lilienthal-Str. 18 Postfach 1120 D- 88677 Markdorf Telephone: +49 7544 5050 Telefax: +49 7544 505200 E-Mail: service.standard@wagner-group.com</p>	<p>Switzerland J. WAGNER AG Industriestrasse 22 Postfach 663 CH- 9450 Altstätten Telephone: +41 (0)71 757 2211 Telefax: +41 (0)71 757 2222 E-Mail: rep-ch@wagner-group.ch</p>
<p>Belgium WAGNER Spraytech Benelux BV Veilinglaan 58 B- 1861 Wolvertem Telephone: +32 (0)2 269 4675 Telefax: +32 (0)2 269 7845 E-Mail: info@wsb-wagner.be</p>	<p>Denmark WAGNER Industrial Solution Scandinavia AB Viborgvej 100, Skoerger DK- 8600 Silkeborg Telephone: +45 702 00245 Telefax: +45 868 56027 E-Mail info@wagner-industri.com</p>
<p>United Kingdom WAGNER Spraytech (UK) Ltd. Haslemere Way Tramway Industrial Estate GB- Banbury, OXON OX16 8TY Telephone: +44 (0)1295 265 353 Telefax: +44 (0)1295 269861 E-Mail: enquiries@wagnerspraytech.co.uk</p>	<p>France J. WAGNER France S.A.R.L. Parc de Gutenberg - Bâtiment F8 8, Voie la Cardon F- 91127 Palaiseau-Cedex Telephone: +33 1 825 011 111 Telefax: +33 1691 946 55 E-Mail: division.solutionsindustrielles@wagner-france.fr</p>
<p>Netherlands WAGNER SPRAYTECH Benelux BV Zonnebaan 10 NL- 3542 EC Utrecht Telephone: +31 (0) 30 241 4155 Telefax: +31 (0) 30 241 1787 E-Mail: info@wsb-wagner.nl</p>	<p>Italy WAGNER COLORA S.r.l Via Fermi, 3 I- 20040 Burago di Molgora (MI) Telephone: +39 039 625021 Telefax: +39 039 6851800 E-Mail: info@wagnercolora.com</p>
<p>Japan WAGNER Spraytech Ltd. 2-35, Shinden Nishimachi J- Daito Shi, Osaka, 574-0057 Telephone: +81 (0) 720 874 3561 Telefax: +81/ (0) 720 874 3426 E-Mail: marketing@wagner-japan.co.jp</p>	<p>Austria J. WAGNER GmbH Otto-Lilienthal-Str. 18 Postfach 1120 D- 88677 Markdorf Telephone: +49 (0) 7544 5050 Telefax: +49 (0) 7544 505200 E-Mail: service.standard@wagner-group.com</p>
<p>Sweden WAGNER Industrial Solutions Scandinavia AB Skolgaten 61 SE- 56831 Skillingaryd Telephone: +46 (0) 421 500 20 Telefax: +46 (0) 370 798 48 E-Mail: info@wagner-industri.com</p>	<p>Spain WAGNER Spraytech Iberica S.A. Ctra. N- 340, Km. 1245,4 E- 08750 Molins de Rei (Barcelona) Telephone: +34 (0) 93 680 0028 Telefax: +34 (0) 93 668 0156 E-Mail: info@wagnerspain.com</p>
<p>Czechoslovakia WAGNER s.r.o. Nedasovská Str. 345 15521 Praha 5 - Zlicin Telephone: +42 (0) 2 579 50 412 Telefax: +42 (0)2 579 51 052 E-Mail: info@wagner.cz</p>	<p>USA WAGNER Systems Inc. 300 Airport Road, unit 1 Elgin, IL 60123 USA Telephone: +1 630 503 2400 Telefax: +1 630 503 2377 E-Mail: info@wagnersystemsinc.com</p>

WAGNER



Order number 383871

Germany

J. WAGNER GmbH
Otto-Lilienthal-Str. 18
Postfach 1120
D- 88677 **Markdorf**
Telephone ++49/ (0)7544 / 5050
Telefax ++49/ (0)7544 / 505200
E-Mail: service.standard@wagner-group.com

Switzerland

J. WAGNER AG
Industriestrasse 22
Postfach 663
CH- 9450 **Altstätten**
Telephone ++41/ (0)71 / 757 2211
Telefax ++41/ (0)71 / 757 2222
E-Mail: rep-ch@wagner-group.ch

www.wagner-group.com